

INSTRUCTION BOOK

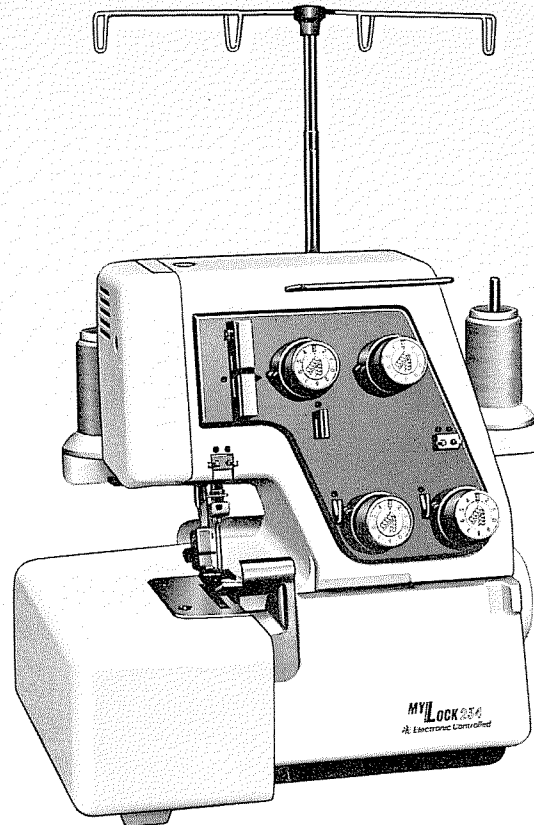

MY/LOCK 234

TABLE OF CONTENTS

PREPARATION

Names of Parts	2
Standard Accessories	3
Attaching the Waste Chip Box	3
Storing the Accessory Box	3
Connecting the Machine to the Power Supply	4
Controlling Sewing Speed	4
How to Turn Balance Wheel	5
Opening and Closing the Side Cover	5
Opening and Closing the Looper Cover	5
The Position of Thread Guide Bar	6
Attaching the Thread Stripping Disc and Net	6
Raising or Lowering the Presser Foot	7
Threading the Machine	7
• Threading the Lower Looper	8~9
• Threading the Upper Looper	10~11
• Threading the Needle on the Right	12~13
• Threading the Needle on the Left	14~15

TEST STITCHING

Starting Sewing	16
Finishing Sewing	16
Sewing Continuously	16
Securing Ends	17~18
Thread Tension (4 threads)	19~21
Thread Tension (3 threads)	22~23
Adjustment of Stitch Length	24
Adjustment of Foot Pressure	24
Removing the Presser Foot	25
Attaching the Presser Foot	25
Changing Needle	26
To Deactivate the Upper Knife	26
To Activate the Upper Knife	27

Types of Needle Plates	27
Changing the Needle Plate	28
Thread and Needle Chart	29

ROLLED HEMMING, PICOT EDGING AND NARROW HEMMING

Machine Setting	30
Thread, Fabric and Range of the Tension Dial	31
Adjusting Thread Tension	32
How to Adjust the Thread Tension	32

DECORATIVE OVEREDGING

Thread, Fabric, Range of the Tension and Machine Setting	33
--	----

PIN TUCKING

Fabric, Thread and Machine Setting	34
Sewing	34

CARE OF YOUR MACHINE

Replacing the Upper Knife	35
Cleaning Upper Knife Area	36
Cleaning the Feed Dog	36
Replacing the Light Bulb	37
Oiling the Machine	38
Trouble Shooting	39

PREPARATION

Names of Parts

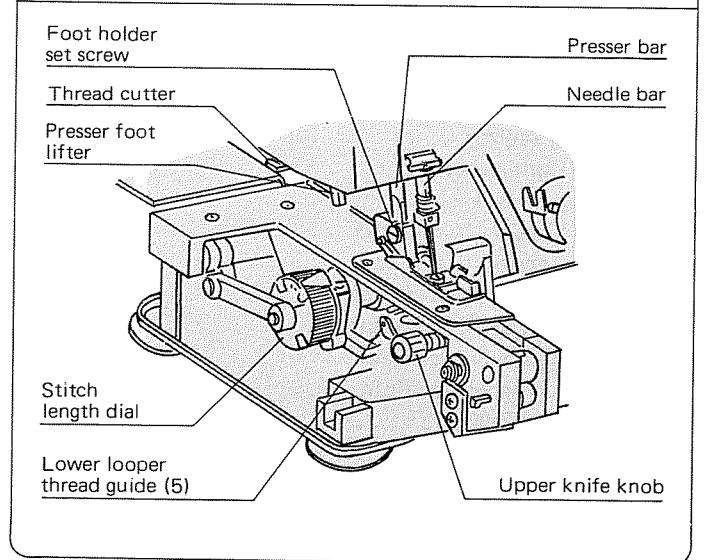
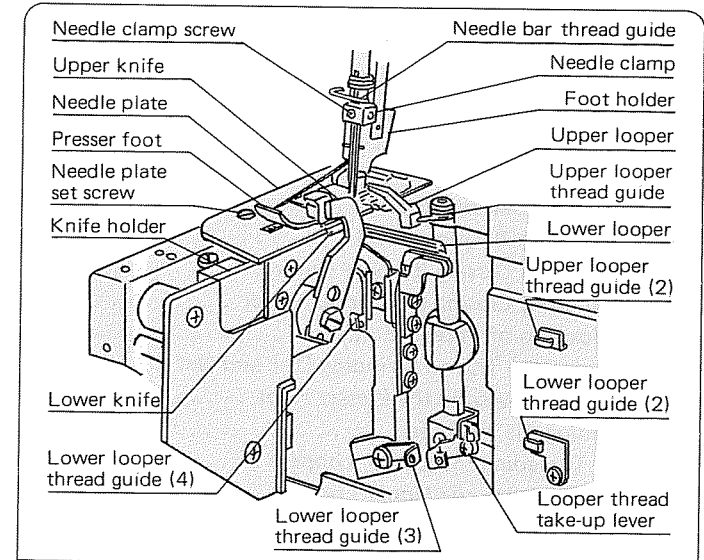
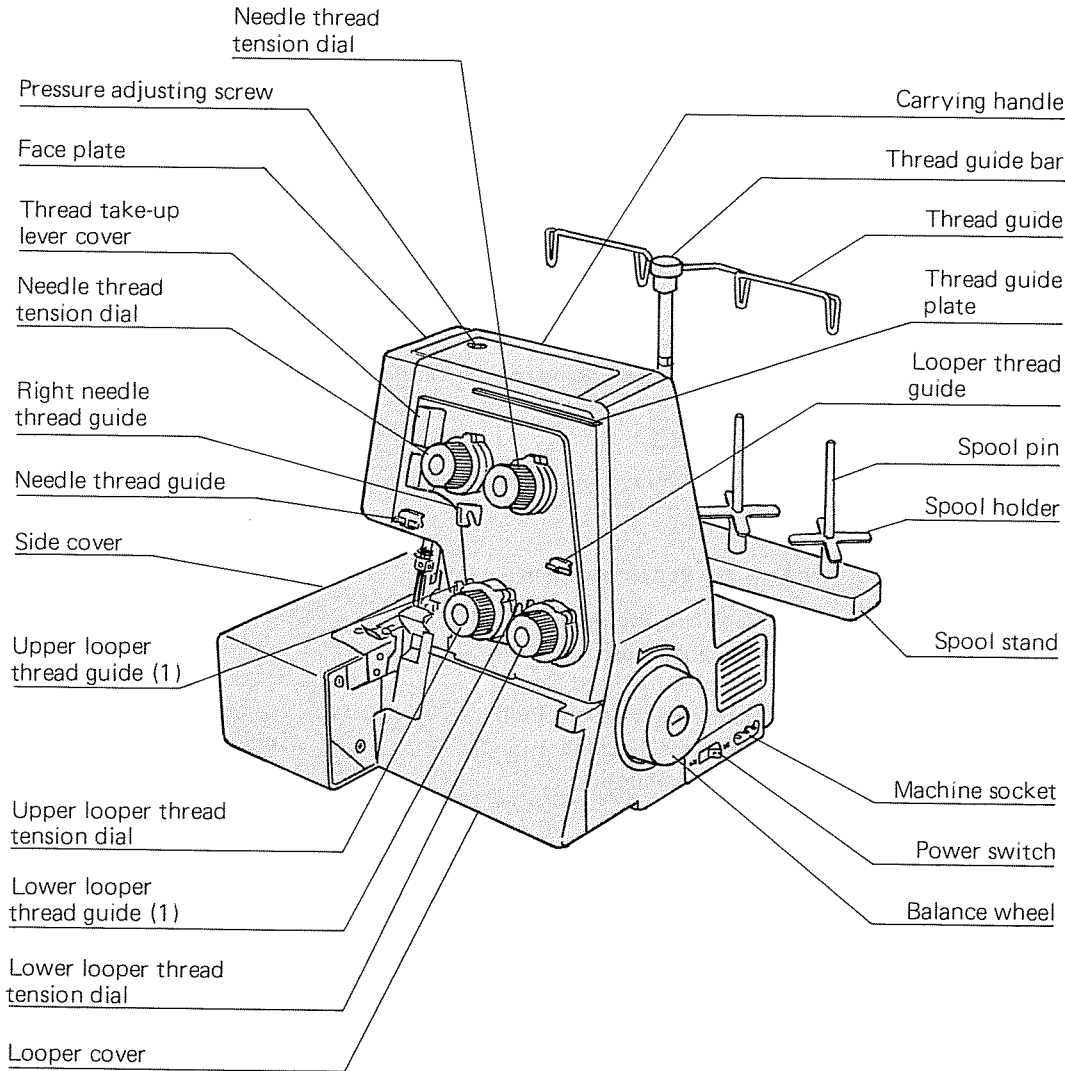

Standard Accessories



Screwdrivers

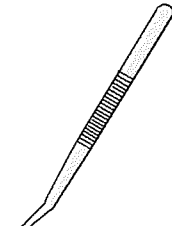

Tweezers

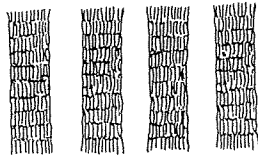

Nets

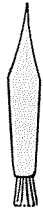

Lint brush



Oil



Upper knife

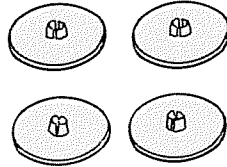

Thread stripping discs

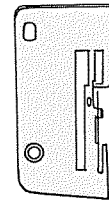

Rolled hemming needle plate



Set of needles

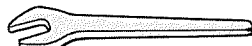

Spanner

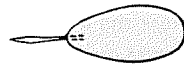

Needle threader

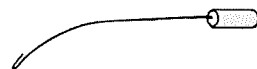

Looper threader

Attaching the Waste Chip Box

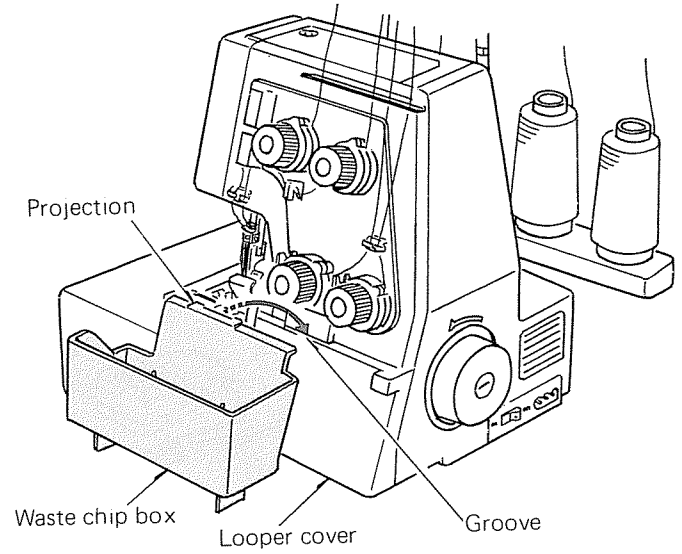

Insert the projection into groove on looper cover.

Storing the Accessory Box

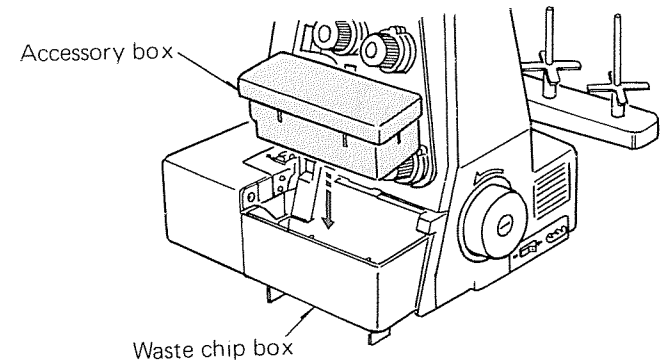

Insert the accessory box into the waste chip box.

Connecting the Machine to the Power Supply

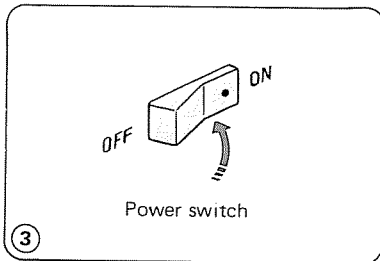
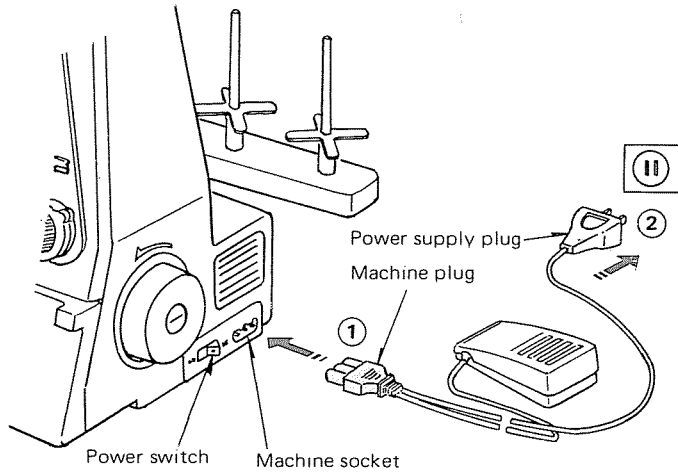

- 1 Turn off the power switch, and connect the machine plug to the machine socket.
- 2 Connect the power supply plug to your power supply.
- 3 Turn on the power switch.

Controlling Sewing Speed

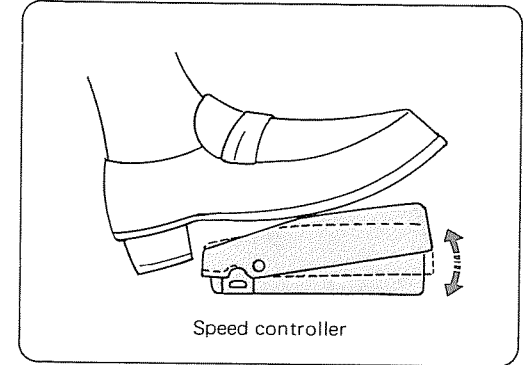

Sewing speed can be varied by the speed controller. The harder you press on the controller, the faster the machine runs.

Step on speed controller with presser foot lifter up, and practice controlling the speed.

For Your Safety:

- * While in operation, always keep your eye on the sewing area, and do not touch any moving parts such as the thread take-up lever, balance wheel, needle or knives.
- * Always disconnect the machine from the power supply:
 - When leaving the machine unattended.
 - When attaching or removing parts.
 - When threading or cleaning the machine.
- * Do not place anything on the speed controller, except in use.

How to Turn Balance Wheel

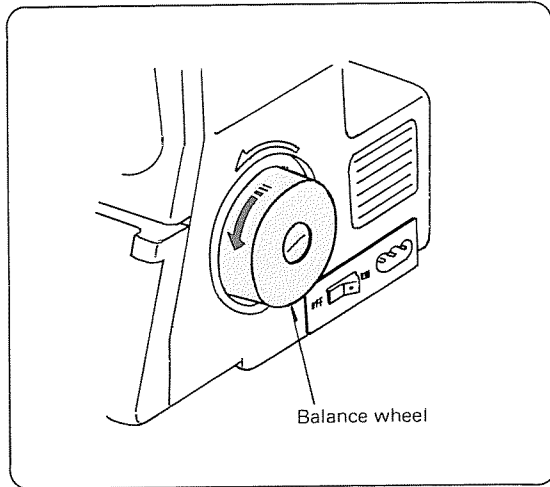

Always turn balance wheel toward you.

Opening and Closing the Side Cover

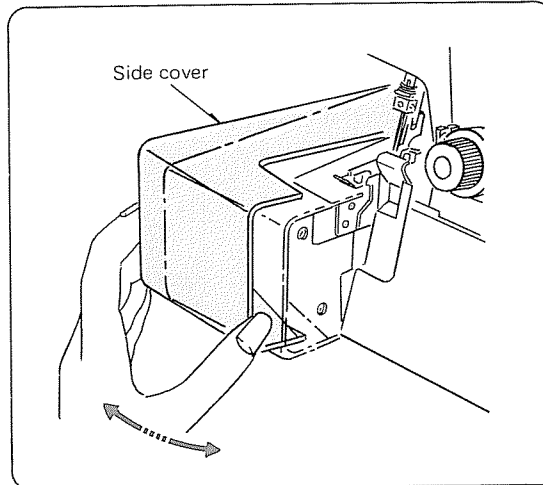

To open:

Push the side cover to the left.

To close:

Push the side cover to the right and slightly toward the machine body.

Opening and Closing the Loper Cover

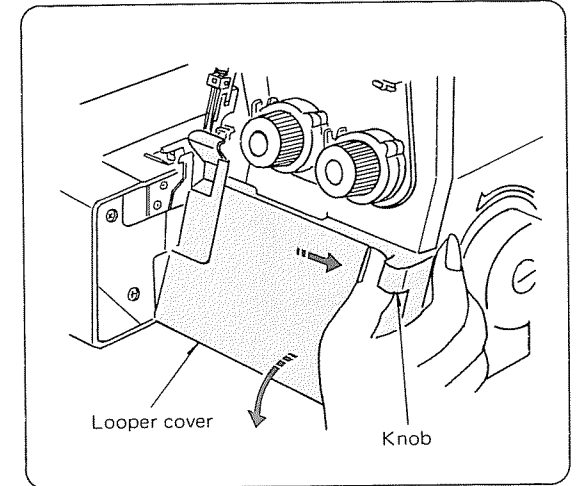

To open:

While pushing the knob to the right as far as it will go, pull looper cover toward you.

To close:

Lift looper cover and push against the machine. The looper cover snaps into the position automatically.

For Your Safety:

Always close the both side and looper covers when the machine is in use.

The Position of Thread Guide Bar

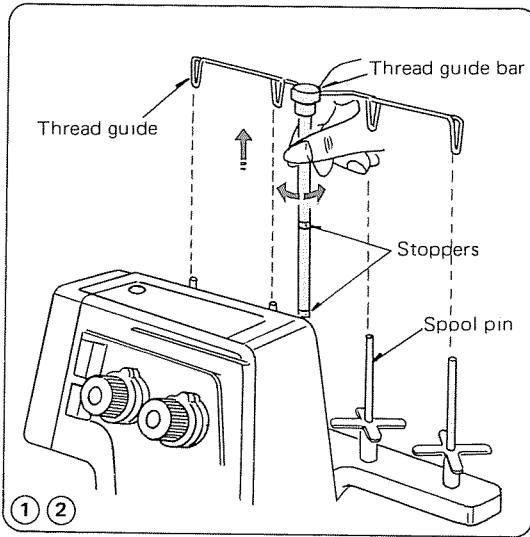

- ① Pull the thread guide bar up as far as it will go.
- ② Turn the thread guide bar so that the thread guides come right above the spool pins.

Attaching the Thread Stripping Disc and Net

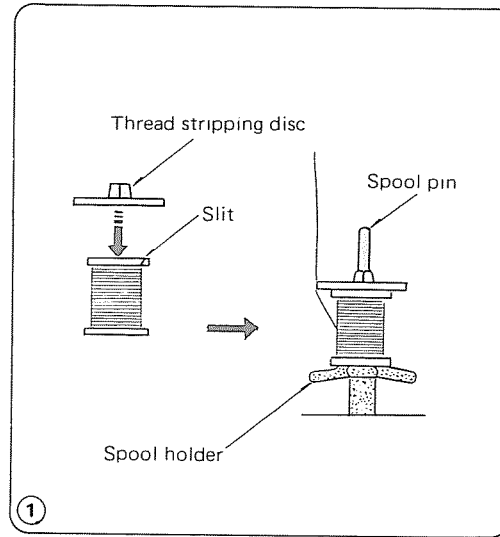

- ① When you use a small thread spool, place it with its slit side up and put the thread stripping disc on top.

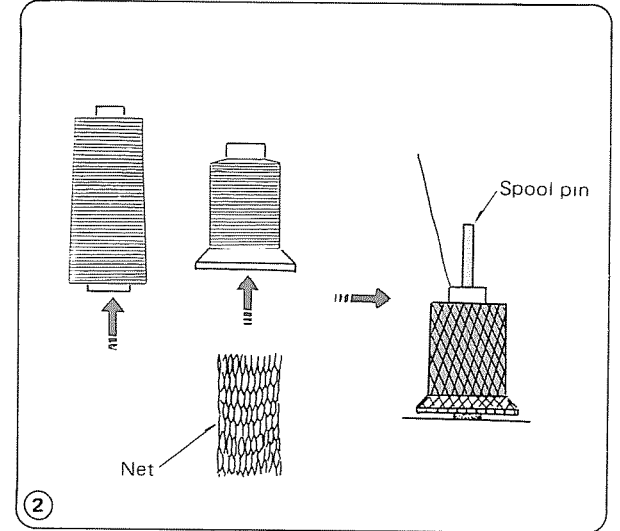

- ② If the thread would slip down from the spool during threading and/or sewing, put a net on the spool as illustrated for preventing jamming. The nets are supplied with the machine.

Raising or Lowering the Presser Foot

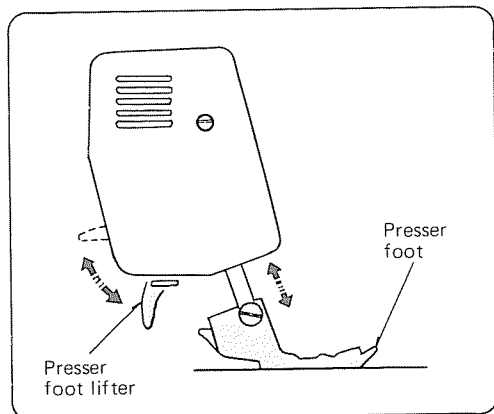

By raising or lowering the presser foot lifter, the presser foot goes up and down respectively.

* While in operation, keep the presser foot lowered except for testing stitches, threading the machine or sewing heavy weight fabrics.

Thread tension will not be released even if the presser foot is raised.

Threading the Machine

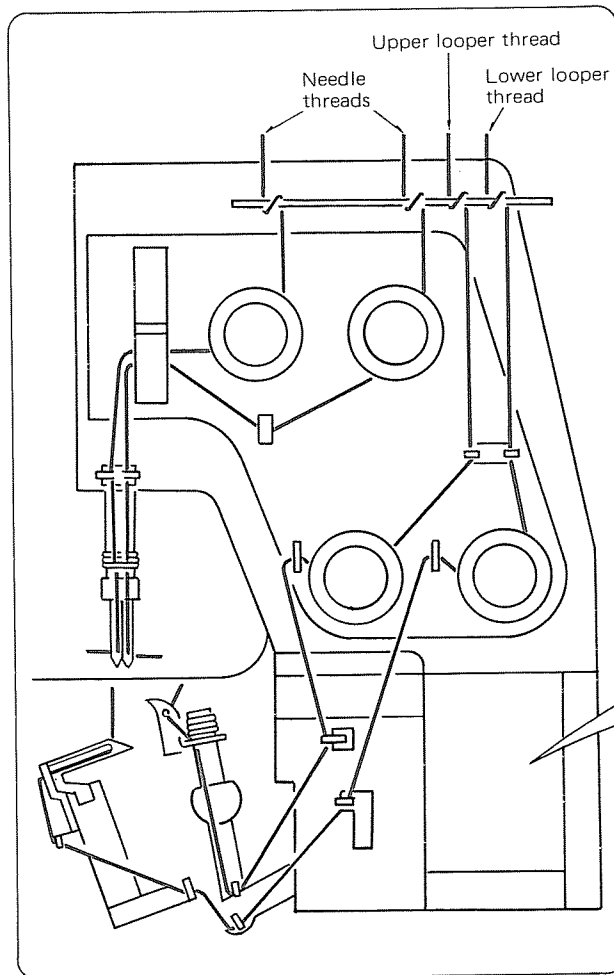

The machine has been threaded and ends of threads have been cut at the factory. To thread the machine knot the end of thread, then pull the other end of thread. For needle threads, pull the other ends of threads until knots come to needle eyes, and cut the threads at the both sides of the knots. Then thread the needle eye with the needle threader. (Refer to page 15.)

This way you can save a time for threading.

Thread lower looper first, then upper looper, needle on the right and needle on the left if the machine is unthreaded. A convenient threading chart is placed on the machine body inside the looper cover.

Incorrect threading will cause of skipped stitch, broken thread or uneven thread tension. Before starting to sew, make sure that your machine is threaded properly.

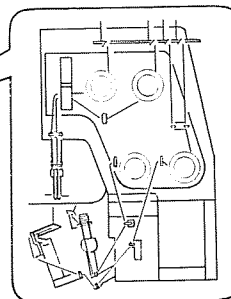

Threading Chart

● **Threading the Lower Looper**

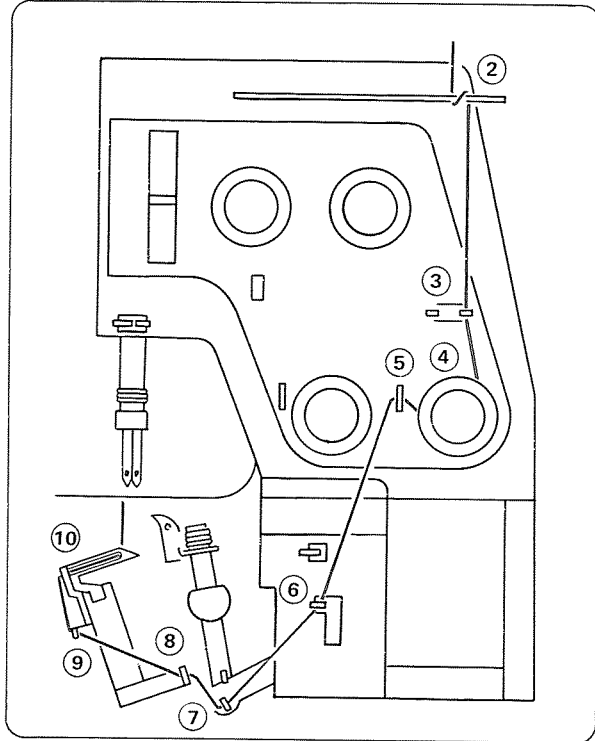

Open the looper and side covers.
Place the spool of thread on the right side spool pin.

* The points to thread for lower looper are marked in green.

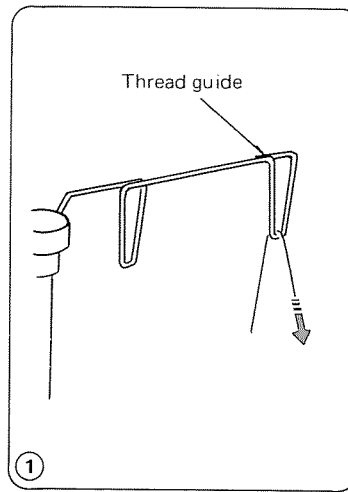

① Draw the thread through the right side thread guide from back to front.

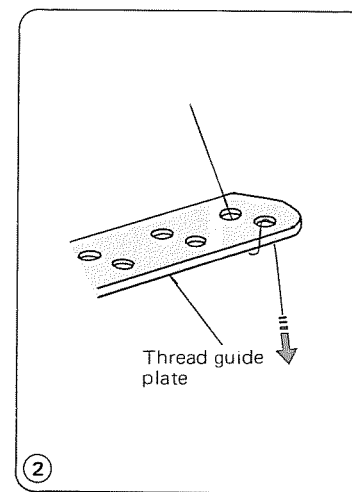

② Pass the thread through holes on the right side of thread guide plate as illustrated.

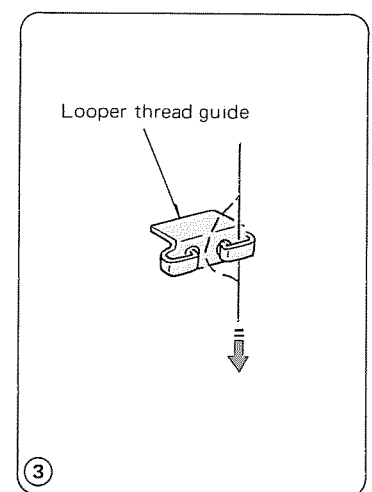

③ Pass the thread through the right side of thread guide sliding the thread from left to right.

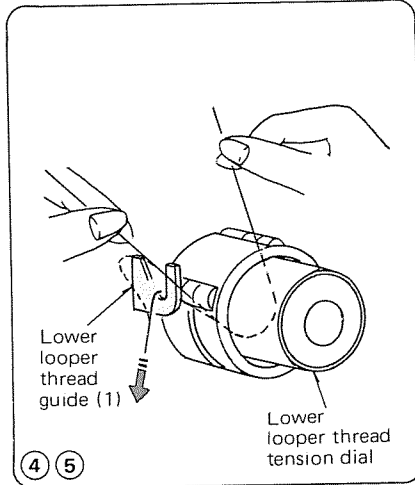

- ④ Insert the thread between tension discs from the right. Then pull the both sides of the thread.
- ⑤ Pass the thread through lower looper thread guide (1).

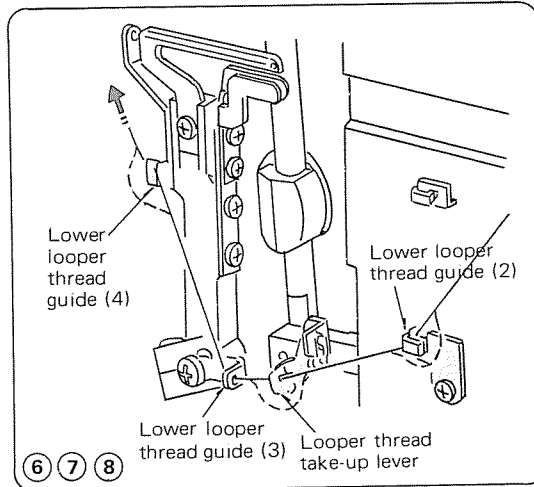

- ⑥ Pass the thread through the thread guide (2).
- ⑦ Pass the thread through the looper thread take-up lever (lower).
- ⑧ Pass the thread through the thread guides (3) and (4).

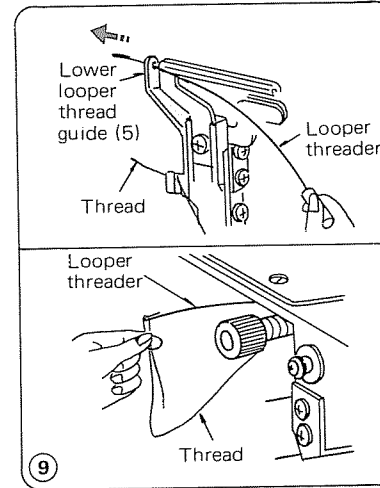

- ⑨ Turn the balance wheel toward you until the lower looper comes to the left, and pass the threader through hole on lower looper thread guide (5). Then hook the end of thread on the threader.

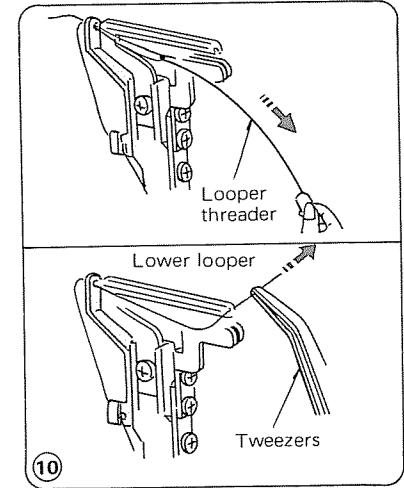

- ⑩ Pull the threader to pass the thread through the hole of lower looper thread guide (5). Remove the thread from the threader, and draw the thread with a pair of tweezers through the hole on lower looper 10 cm (4") or more.

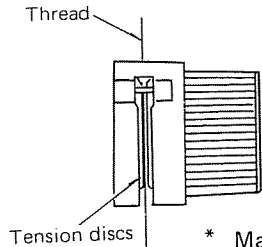

* Make sure that the thread is between the tension discs.

How to Thread the Woolly Nylon/Polyester Thread

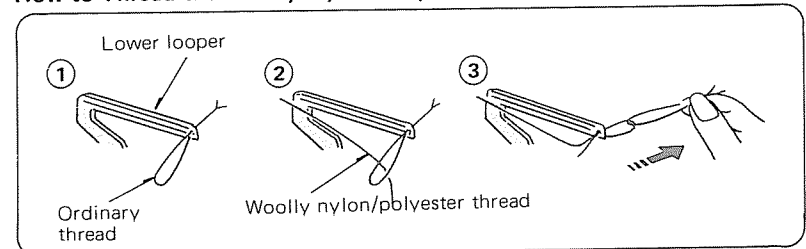

- * To pass the woolly nylon/polyester thread shown above is one of the easiest ways to do so.
- * Apply the same method to the upper looper.

● Threading the Upper Looper

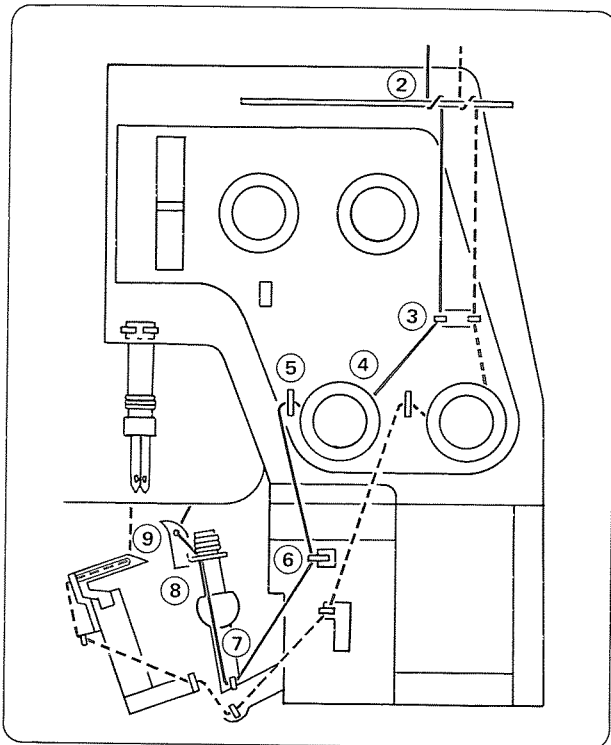

Place the spool of thread on the spool pin second from the right.

* The points to thread for upper looper are marked in blue.

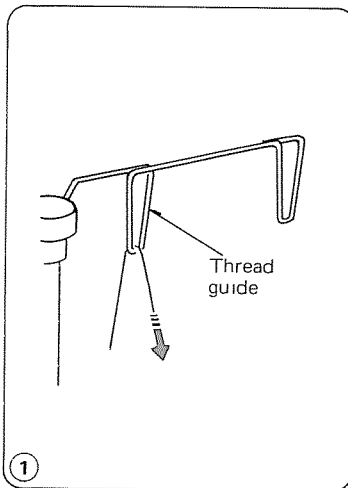

① Draw the thread through the thread guide second from the right from back to front.

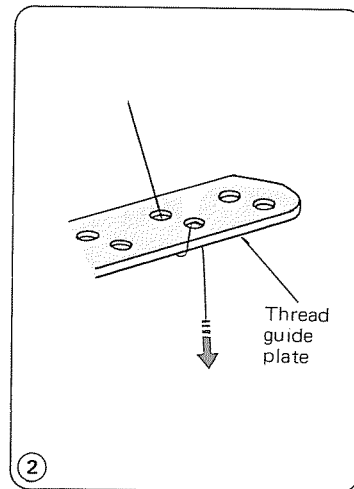

② Pass the thread through the holes in the second row from the right of thread guide plate as illustrated.

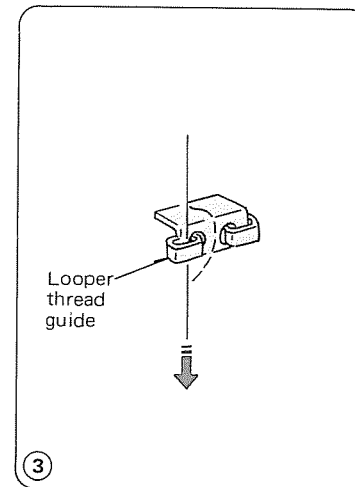

③ Pass the thread through the left side of thread guide sliding the thread from right to left.

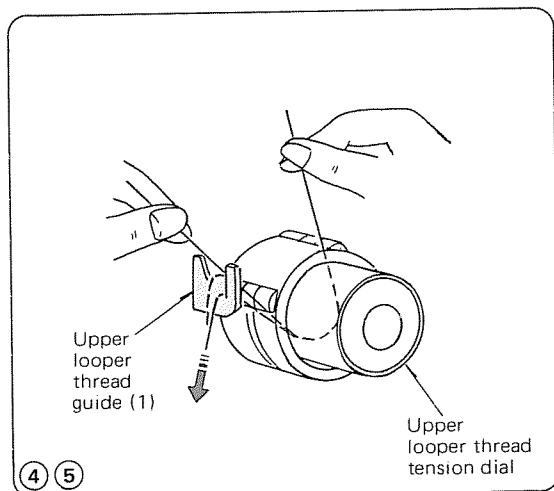

- ④ Insert the thread between tension discs from the right. Then pull the both sides of thread.
- ⑤ Pass the thread through upper looper thread guide (1).

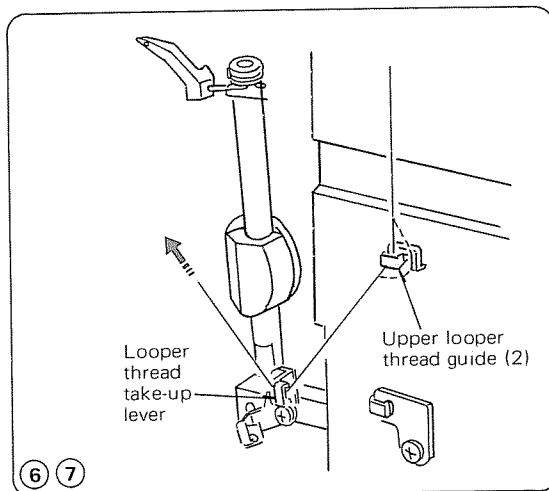

- ⑥ Pass the thread through upper looper thread guide (2).
- ⑦ Pass the thread through the looper thread take-up lever (upper).

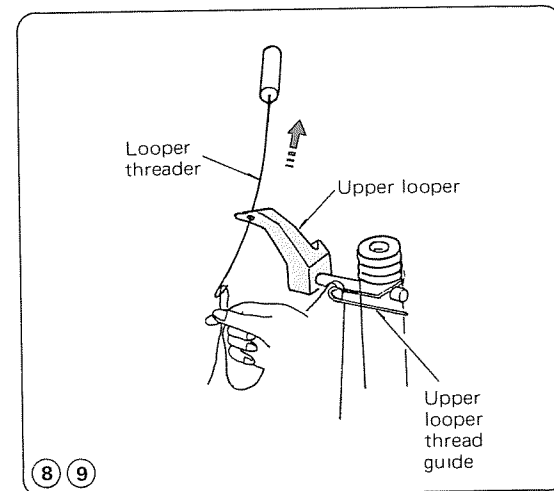

- ⑧ Pass the thread through upper looper thread guide.
- ⑨ Pass the threader through the hole on the upper looper. Then hook the end of thread on the threader. Pull out the threader to pass the thread through the hole. Remove the thread from threader, and draw the free end of thread 10 cm (4") or more.

● Threading the Needle on the Right

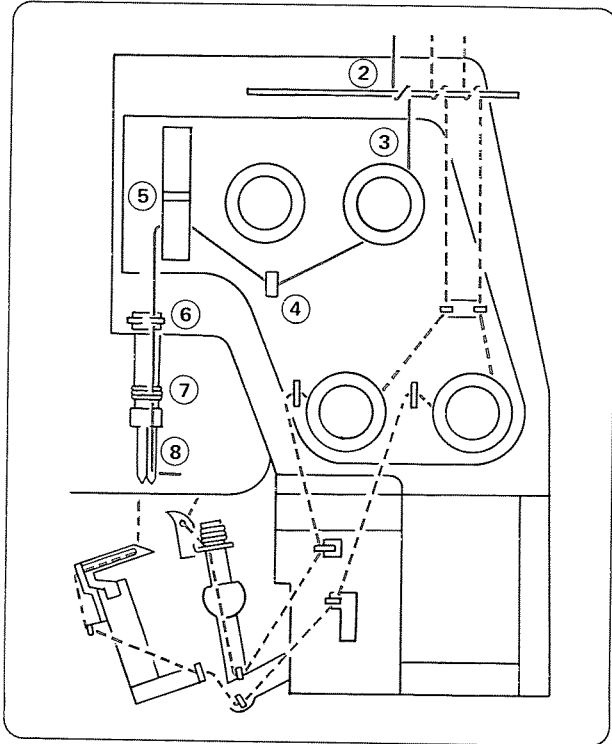

Place the spool of thread on the spool pin second from the left.

* The points to thread for needle on the right are marked in orange.

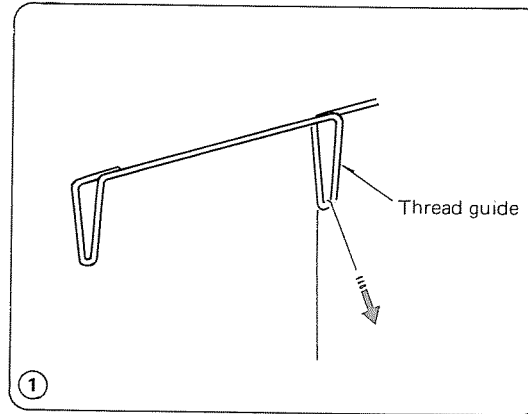

① Draw the thread through the thread guide second from the left from back to front.

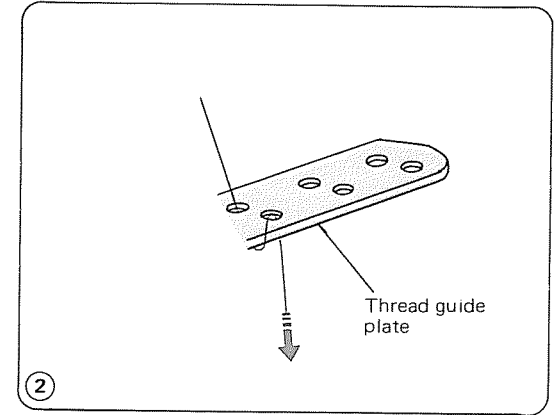

② Pass the thread through the holes in the second row from the left of thread guide plate as illustrated.

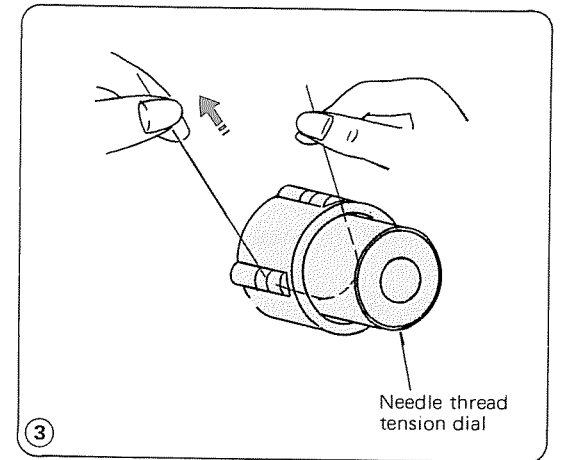

③ Insert the thread between tension discs from the right. Then pull the both sides of thread.

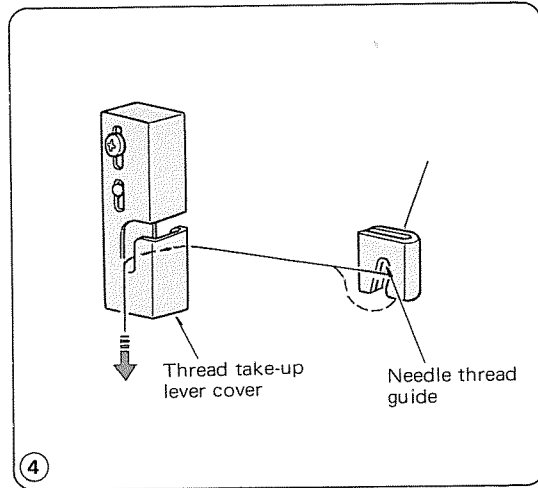

④ Turn the balance wheel toward you to bring needle bar at its highest position, then pass the thread through needle thread guide and thread take-up lever cover.

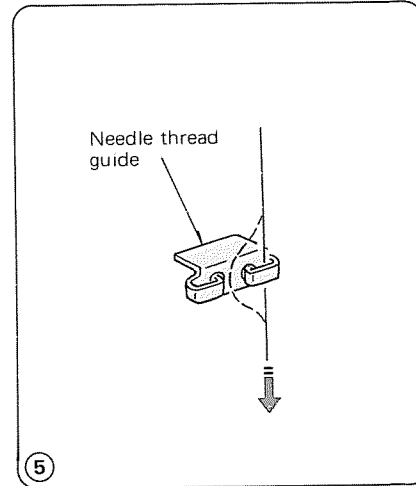

⑤ Pass the thread through the thread guide sliding the thread from left to right.

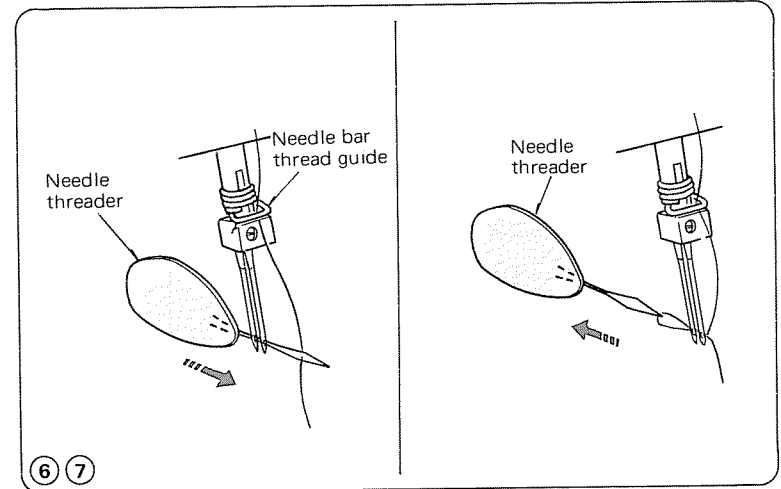

⑥ Pass through needle bar thread guide.

⑦ Pass the threader through the needle eye from back to front. Pass the end of thread through the loop of threader, then pull the threader to the back to pass the thread through needle eye. Draw the free end of thread 10 cm (4") or more.

● **Threading the Needle on the Left**

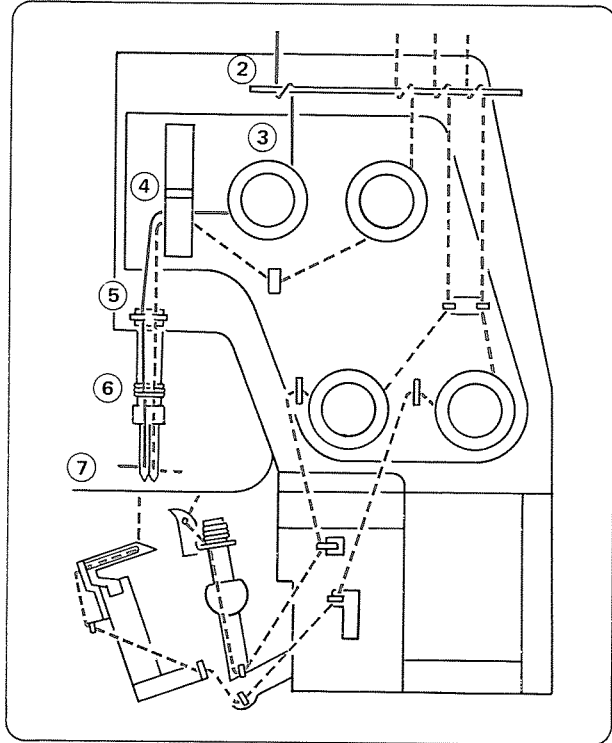

Place the spool of thread on the left side spool pin.

* The points to thread for needle on the left are marked in red.

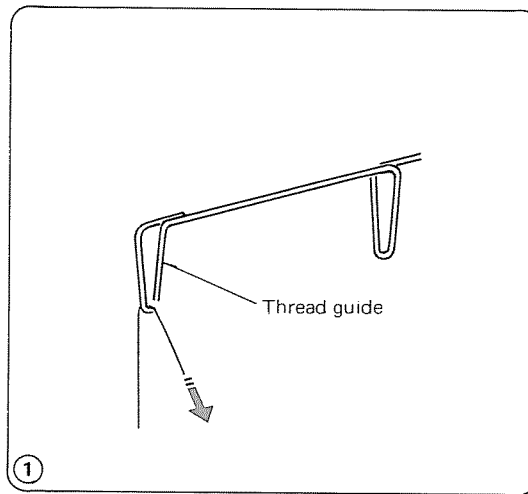

① Draw the thread through the thread guide on the left from back to front.

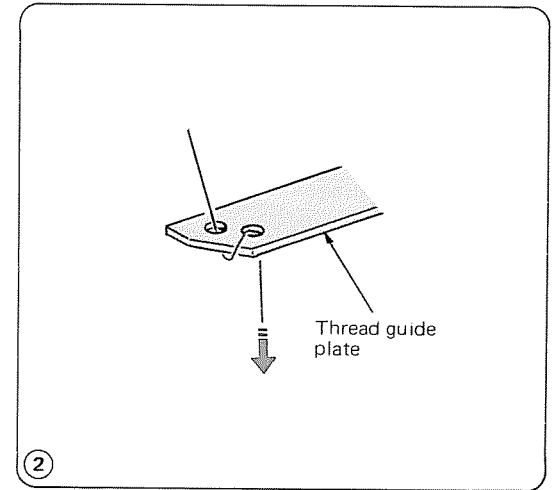

② Pass the thread through the holes on the left of thread guide plate as illustrated.

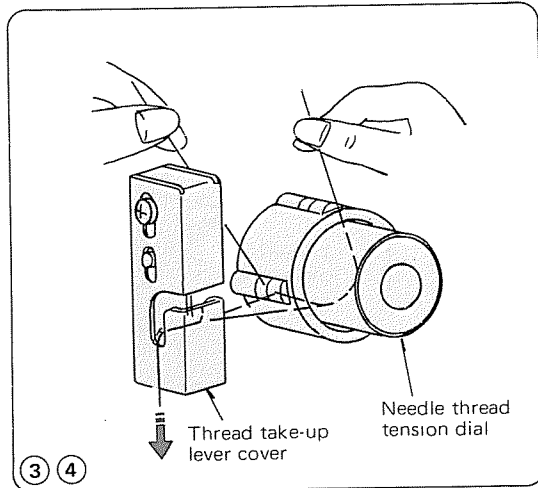

- ③ Insert the thread between tension discs from the right. Then pull the both sides of thread.
- ④ Turn the balance wheel toward you to bring needle bar at its highest position, then pass the thread through thread take-up lever cover.

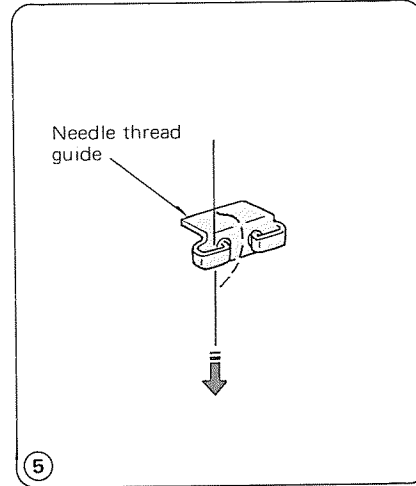

- ⑤ Pass the thread through the thread guide sliding the thread from right to left.

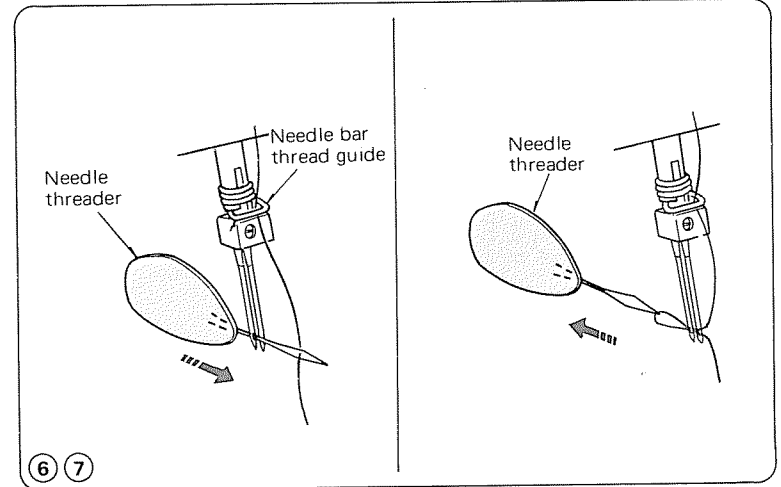

- ⑥ Pass through needle bar thread guide.
- ⑦ Pass the threader through the needle eye from back to front. Pass the end of thread through the loop of threader, then pull the threader to the back to pass the thread through needle eye. Draw the free end of thread 10 cm (4") or more. Close the both side and looper covers.

TEST STITCHING

Starting Sewing

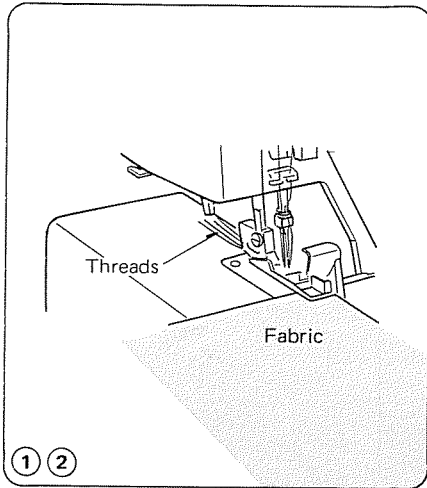

- ① Insert the fabric under the toe of the foot.
(It is not necessary to raise the foot.)
- ② Turn the balance wheel gently toward you a couple of turns and check the thread chain. Then start sewing slowly. The fabric will be automatically fed. Guide the fabric in the direction desired.

Finishing Sewing

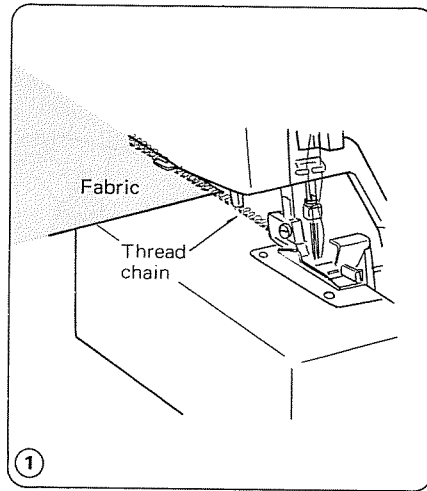

- ① When stitching is completed, continue to run the machine slowly to produce a thread chain for about 12 cm (5") while pulling the thread chain slightly to the back.

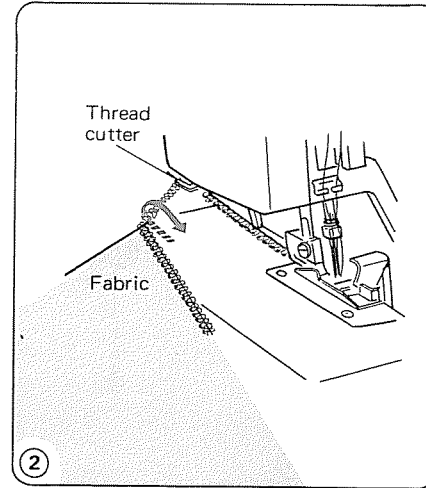

- ② Cut the threads with the thread cutter as illustrated, leaving about 5 cm (2") thread chain from the end of fabric.

Sewing Continuously

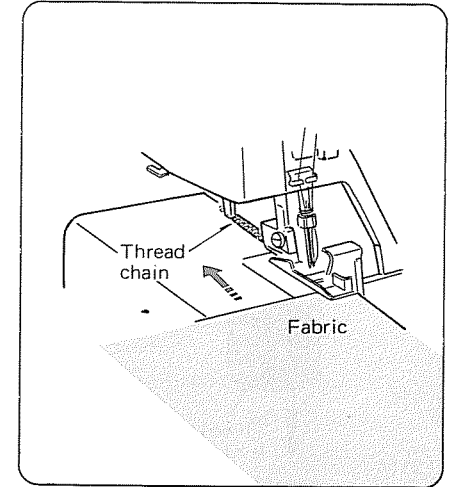

Insert next fabric under the toe of foot, then start sewing. It is not necessary to raise the presser foot for ordinary fabric.

- * For heavy weight fabric, raise the presser foot and insert the fabric in front of the knife. Then lower the foot and sew.

Securing Ends

To avoid unravelling, it is necessary to leave a thread chain about 5 cm (2") long at the beginning and end of seam. To secure the beginning and end of a seam choose one of the following methods.

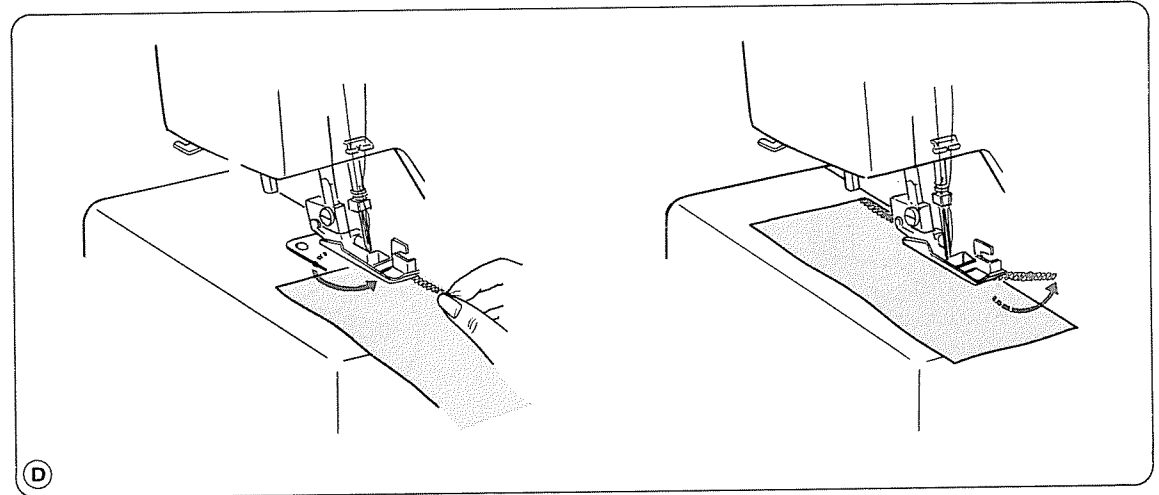
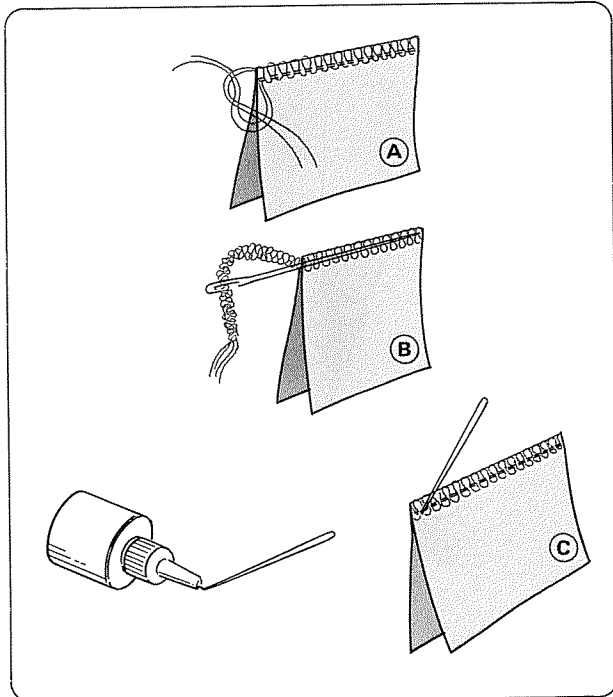

At the Beginning

- A. Separate the end of threads and knot.
- B. Thread the chain through a large eyed needle, and weave that chain through the overlock stitches on the fabric.
- C. Cut the chain at the edge of fabric. Then apply a small amount of seam sealant (Fray Check TM) on the end of the threads.
- D. Backstitching
 1. Before putting your fabric in the machine, sew a thread chain about 5 cm (2") long behind the needle.
 2. Put your fabric in the machine. Then serge a few stitches and stop.
 3. Raise the presser foot and bring the thread chain to the left around and under the presser foot.
 4. Place the thread chain between the presser foot and upper knife, holding it in position as you lower the presser foot to sew.
 5. After sewing about 2.5 cm (1"), move the chain to the right and under the upper knife, cutting the chain as you sew.

Securing Ends (continued)

At the End

You can use the same methods as At the beginning to secure the end of seam except "Backstitching", or the methods shown below.

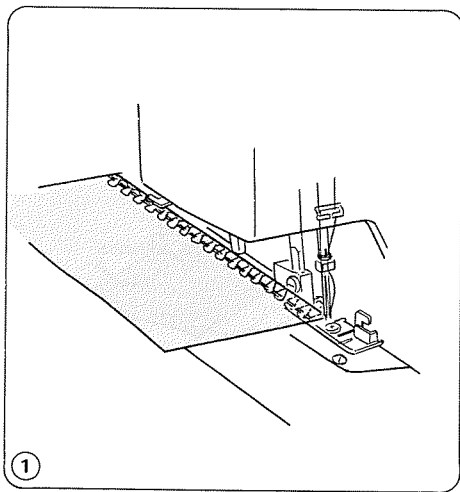

① Serge one stitch off the end of seam.

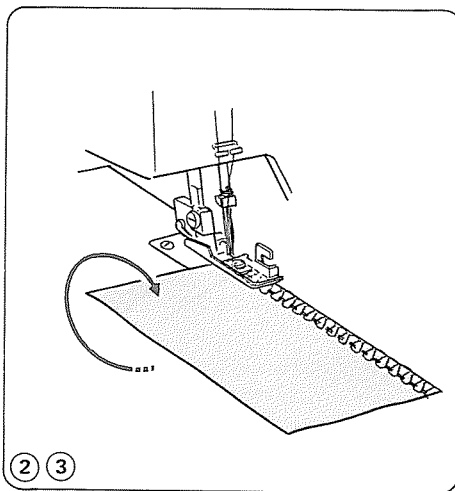

② Raise the needle and presser foot, and gently pull the threads off the prong.

③ Turn the fabric over so that the under side is up.

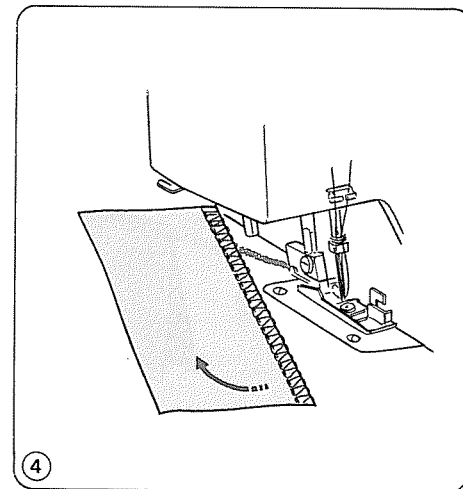

④ Serge about 2.5 (1") over stitching and angle off the fabric.

Thread Tension (4 threads)

Thread Tension Dial

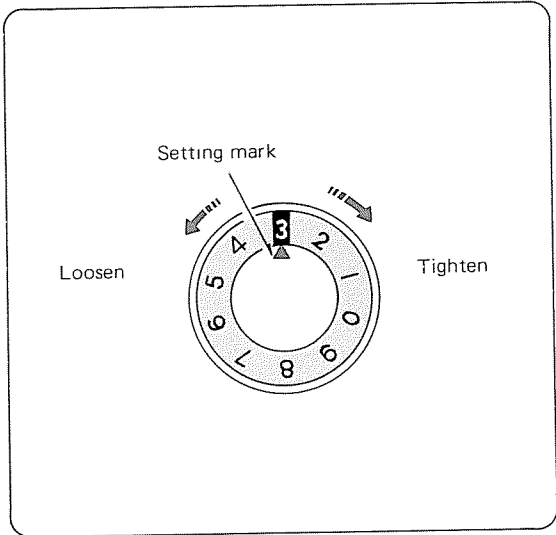

Correct Tension

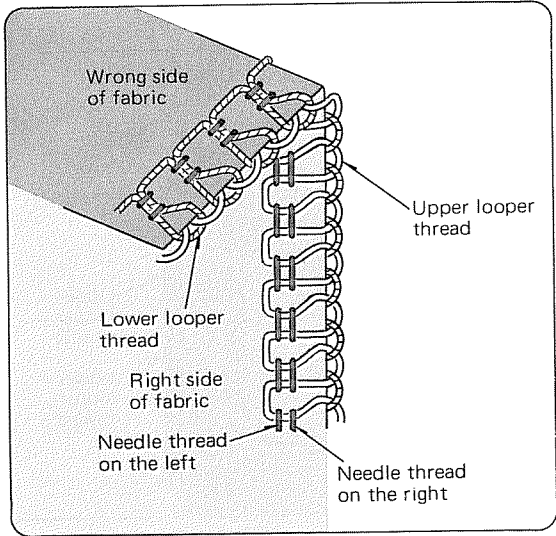

Thread Tension

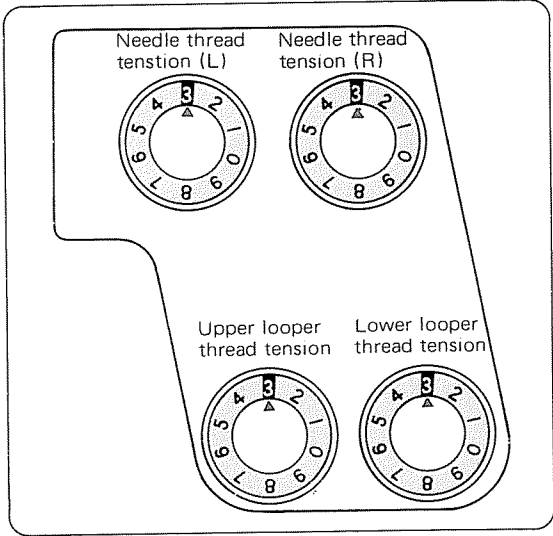

Adjusting the thread tension may be required depending on the type of fabric and thread being used. Refer to pages 20 and 21 for the adjustment.

Thread Tension (continued)

Thread Tension Adjustment

* Set all four thread tension dials at "3". Then sew, and check the thread tensions.

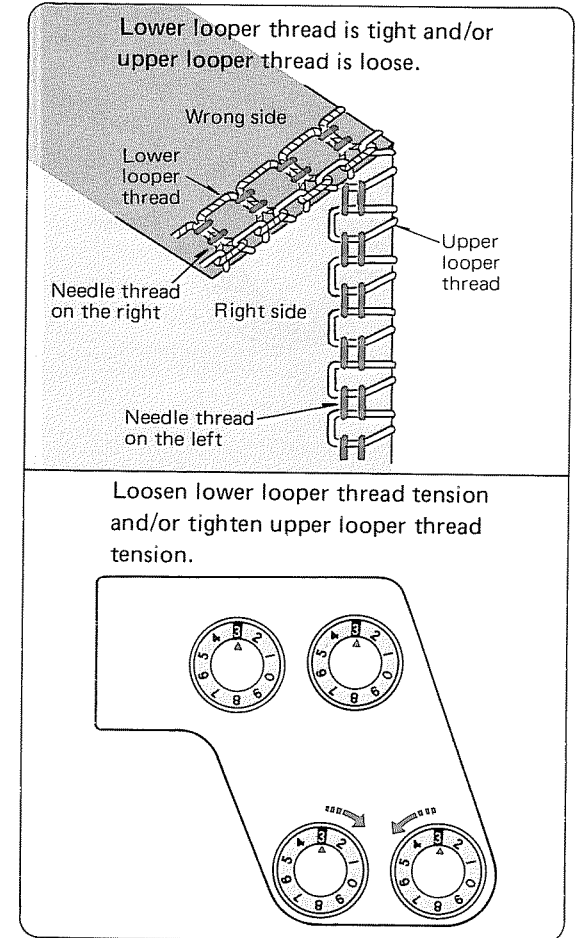
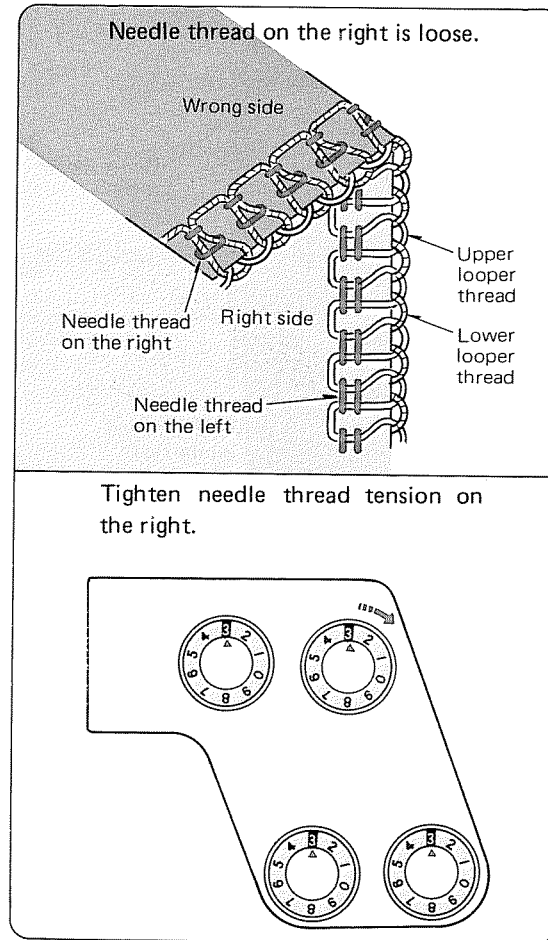
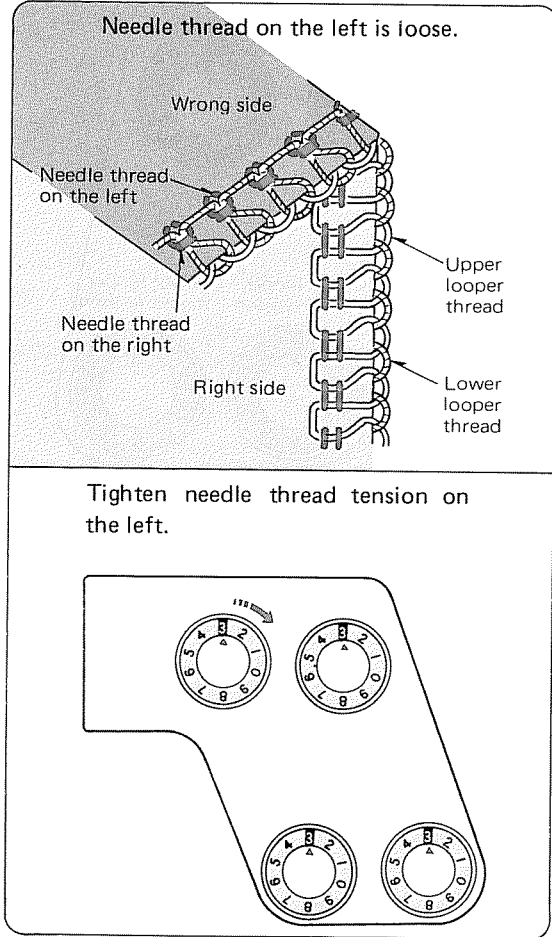

* It is easier to adjust by using 4 different colors of thread.

Upper looper thread is tight and/or lower looper thread is loose.

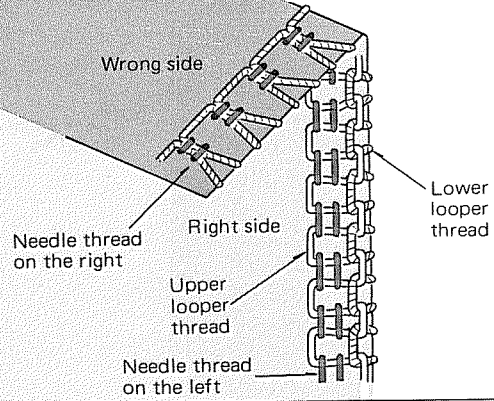

Loosen upper looper thread tension and/or tighten lower looper thread tension.

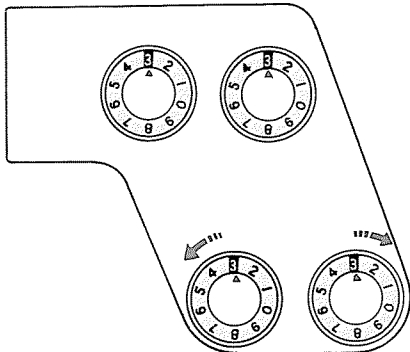

Thread Tension (3 threads)

Using the Needle on the Right Only

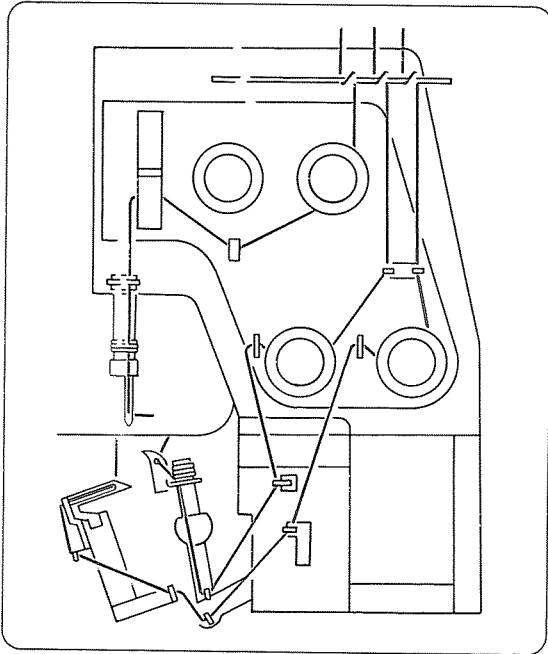

Using the Needle on the Left Only

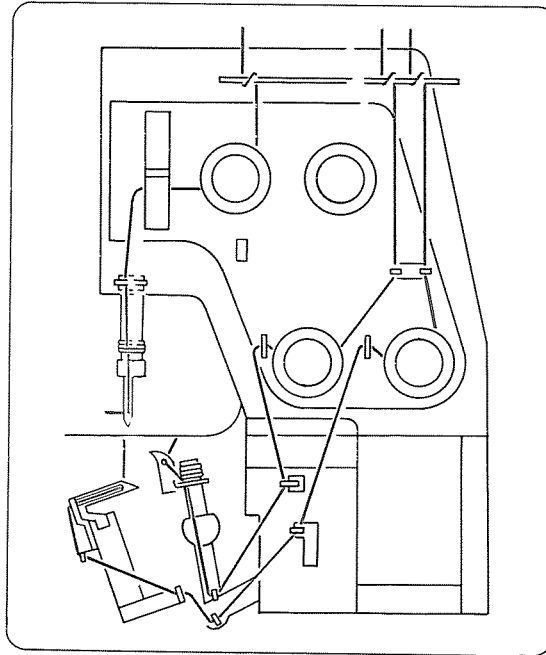

Correct Tension

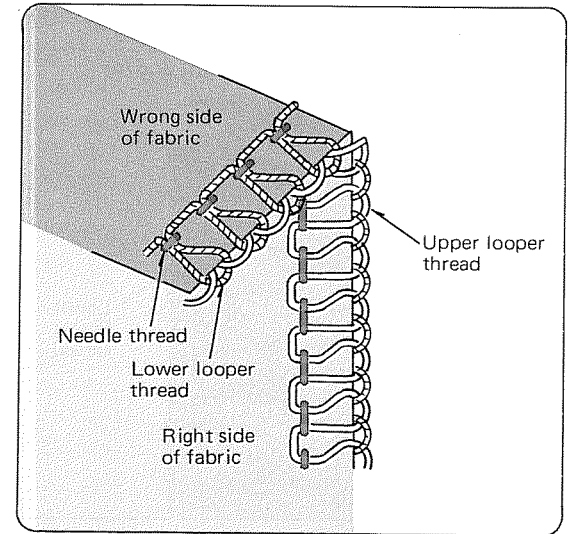

Adjusting the thread tension may be required depending on the type of fabric and thread being used.

Refer to page 23 for the adjustment.

Thread Tension Adjustment

* Set all three thread tension dials at "3". Then sew, and check the thread tensions.

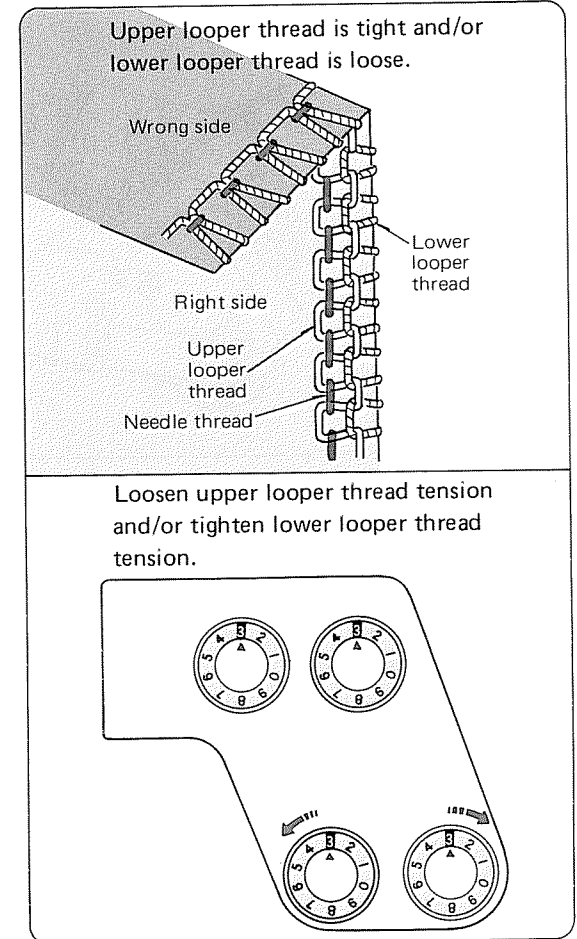
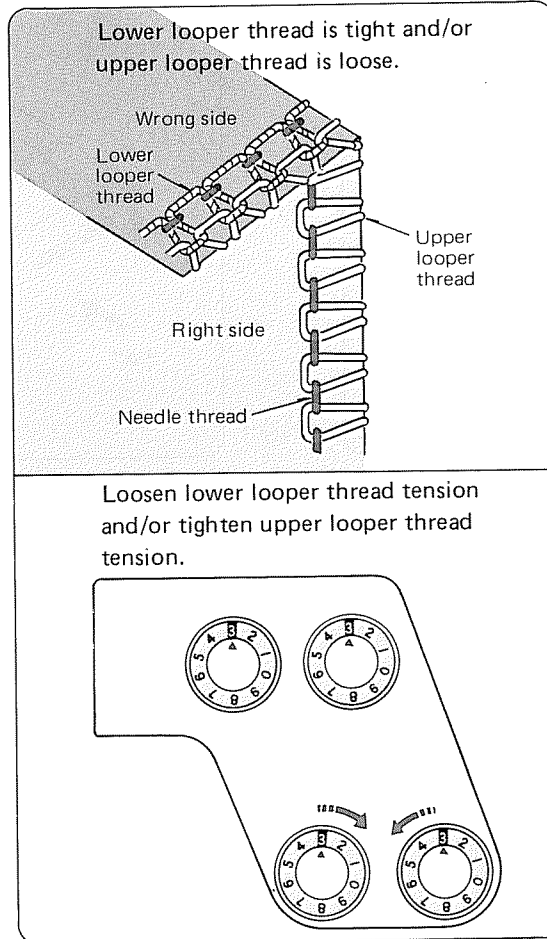
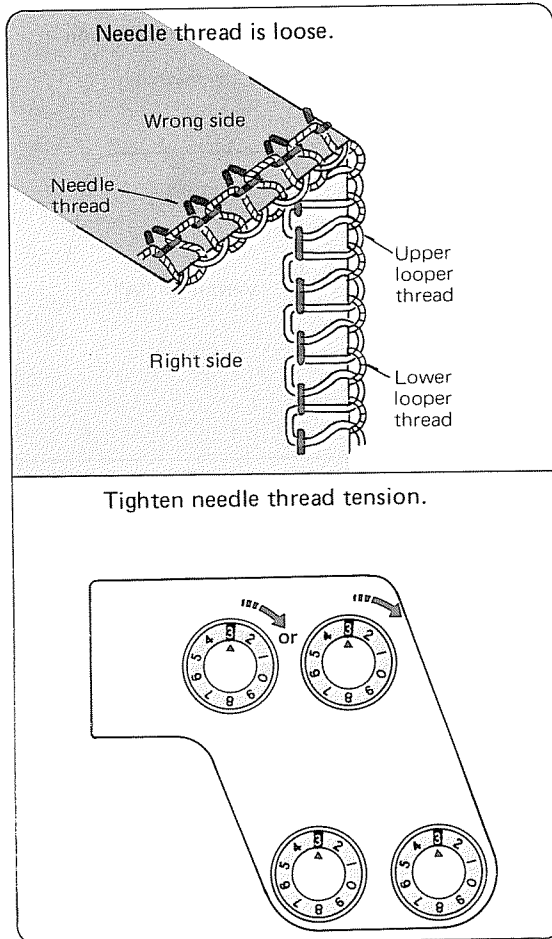

* It is easier to adjust by using 3 different colors of thread.

Adjustment of Stitch Length

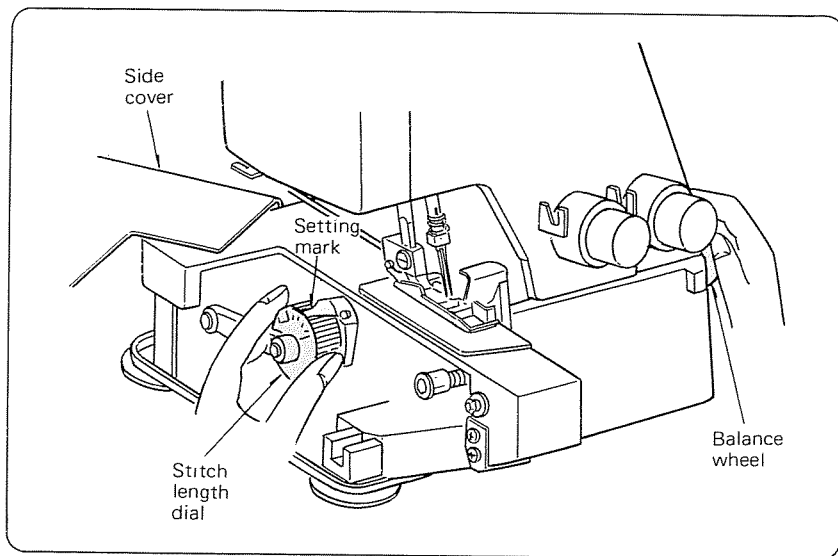

- 1 Disconnect the machine from the power supply.
- 2 Open the side cover.
- 3 Turn the balance wheel with your right hand while holding the stitch length dial with your left hand.
As you turn the balance wheel, the setting mark moves. Set the dial to "3" for normal sewing.

Stitch Length Dial

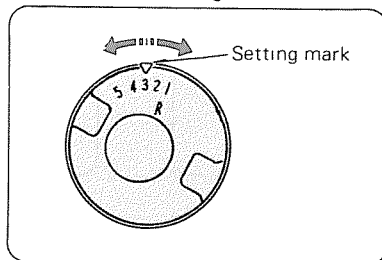

Adjustment of Foot Pressure

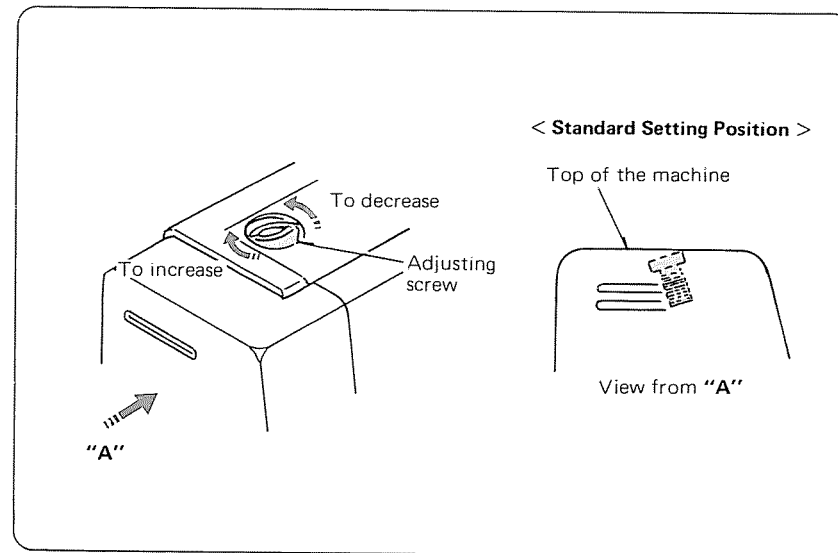

It is not necessary to adjust the pressure for normal sewing.

When you sew heavy or light weight fabrics, turn the adjusting screw to:

- clockwise for heavyweight fabric.
- counter-clockwise for lightweight fabric.

* For normal sewing, leave the adjusting screw in the position that the surface of top of the machine and the top of the adjusting screw is in the same level as illustrated.

Removing the Presser Foot

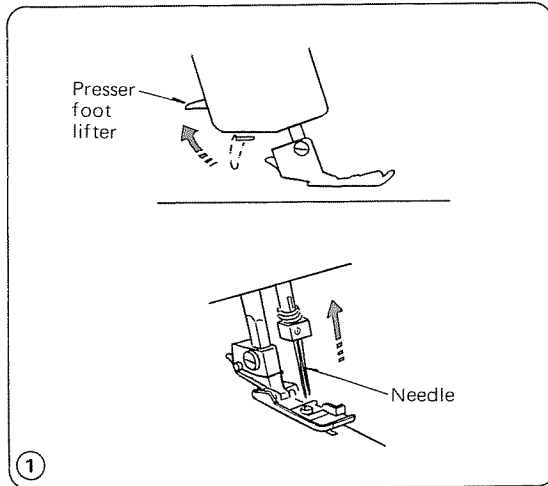

① Raise the needle and presser foot.

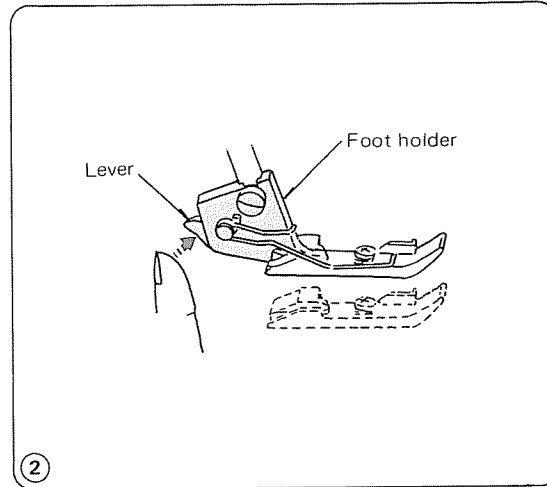

② Press the lever located on the back of foot holder. The presser foot will drop off.

Attaching the Presser Foot

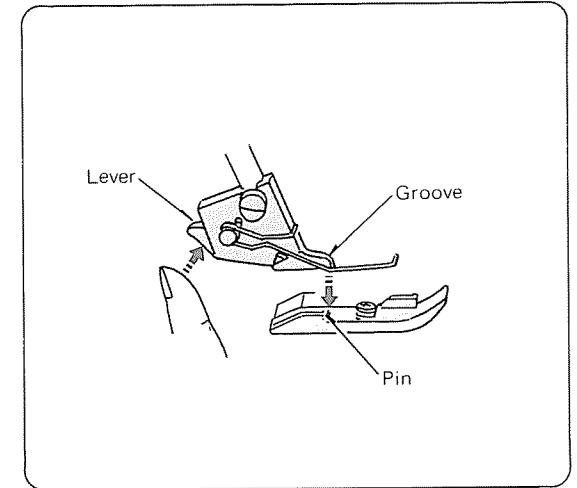

Place the presser foot so that the pin on the foot lies just under the groove of the foot holder. Lower the foot holder and push the lever to lock the foot in place. Raise the presser foot lifter and see the presser foot is in place.

Changing Needle

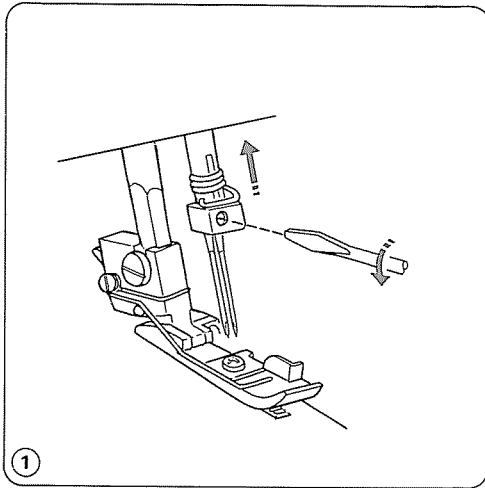

- ① Disconnect the machine from the power supply. Raise the needle bar above the presser foot, and loosen the needle clamp screw, then remove the needles.

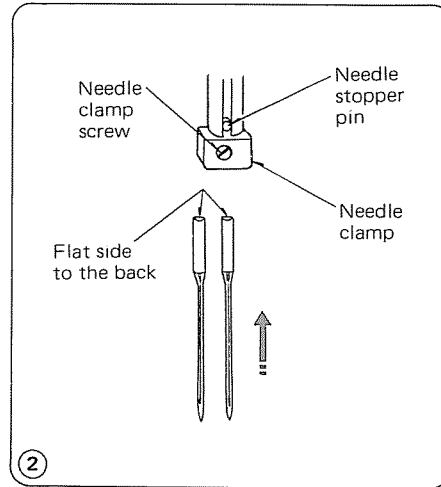

- ② Insert new needles into the needle clamp with its flat side to the back as far as they will go, then tighten the needle clamp screw.

* When the needles are set correctly, the left side needle is higher than the right side one.

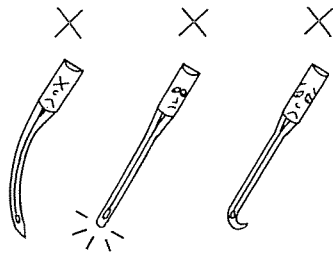

* Do not use any needle which is bent or blunt.

To Deactivate the Upper Knife

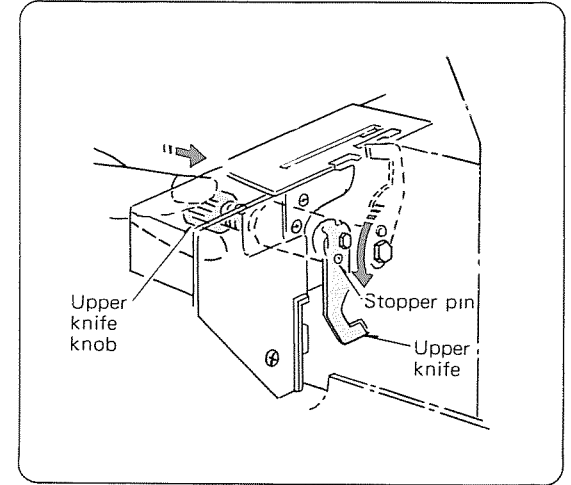

- ① Disconnect the machine from the power supply.
 ② Open the looper and side covers.
 ③ Turn the upper knife knob toward you while pushing it to the right, then guide the hole on upper knife to the pin to lock the upper knife in down position.
 ④ Close the looper and side covers.

To Activate the Upper Knife

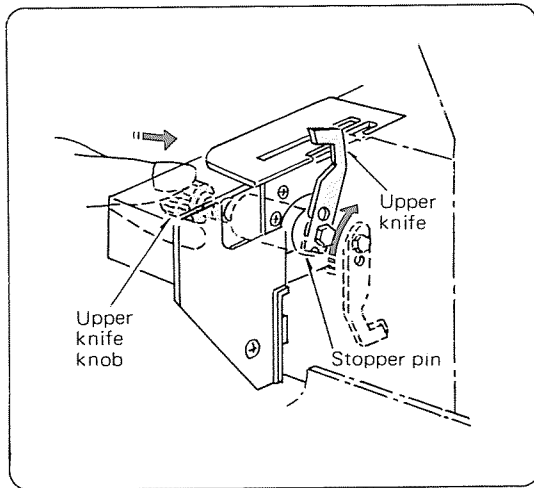

- ① Disconnect the machine from the power supply.
- ② Open the looper and side covers.
- ③ Turn the upper knife knob away from you while pushing it to the right, then guide the groove on upper knife to the pin to lock upper knife in the up position.
- ④ Close the looper and side covers.

Types of Needle Plates

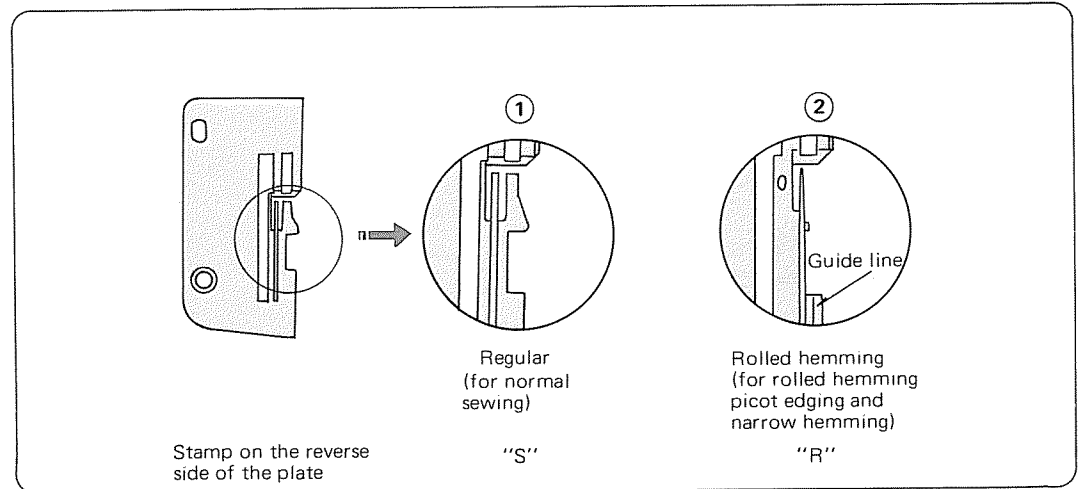

- * Select the needle plate for your sewing need.
- * The regular needle plate has been set to the machine.

For your Safety:

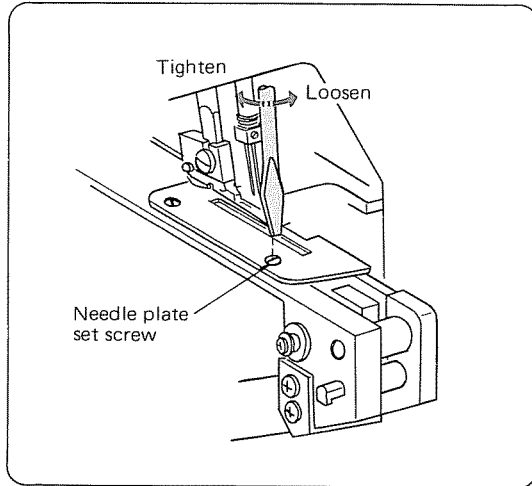

When you change the needle plate or adjusting the seam width, make sure that the machine is disconnected from the power supply.

Changing the Needle Plate

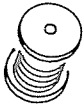
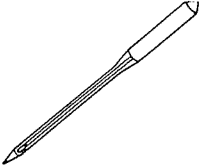

- ① Turn the balance wheel toward you until the needle comes above the needle plate. Then remove the presser foot.
- ② Open the side and looper covers.
(Refer to page 5.)
- ③ Set the upper knife to down position.
(Refer to page 26.)
- ④ Remove the needle plate set screw, and lift the needle plate.
- ⑤ Attach the needle plate you require with the needle plate set screw.
- ⑥ Bring the upper knife to up position.
(Refer to page 27.)
- ⑦ Close the looper and side covers.
- ⑧ Attach the presser foot.

Thread and Needle Chart

Type of Fabric		Type of Thread 	Needle 	Stitch Length 
Light weight	Organdy, Georgette, Lawn, Crepe de chine, Lining.	Cotton : No. 80 ~ 100 Silk : No. 80 ~ 100 Synthetic : No. 80 ~ 100	HA-1 SP No. 11	2.0 ~ 3.0 mm
Medium weight	Cotton, Linen, Satin, Ordinary fabric.	Cotton : No. 60 ~ 100 Silk : No. 50 ~ 100 Synthetic : No. 60 ~ 100	HA-1 SP No. 11 ~ 14	2.5 ~ 3.5 mm
Heavy weight	Tweed, Coating, Denim, Doeskin, Thick fabric.	Cotton : No. 50 ~ 60 Silk : No. 50 ~ 60 Synthetic : No. 50 ~ 60	HA-1 SP No. 14	3.0 ~ 4.0 mm
Knits	Knitted fabric	Cotton : No. 60 ~ 80 Synthetic : No. 60 ~ 90 Woolly nylon (For looper thread) Woolly polyester (For looper thread)	HA-1 SP No. 11 ~ 14	2.5 ~ 3.5 mm

* Refer to page 24 for adjusting the stitch length.

ROLLED HEMMING, PICOT EDGING AND NARROW HEMMING

Machine Setting

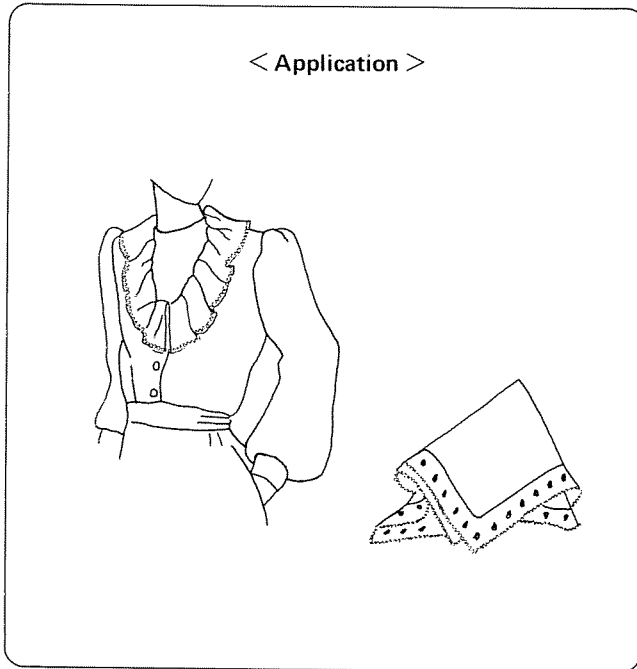

	Rolled Hemming	Picot Edging	Narrow Hemming
Stitch Length	 (R)	 (3 ~ 4)	 (R)
Needle	Remove the needle on the left hand side.		
Needle Plate	 Rolled hemming needle plate.		

* Refer to page 28 for changing the needle plate.

Thread, Fabric and Range of the Tension Dial

The setting of tension dials may vary depending on the type and thickness of fabric and thread being sewn.

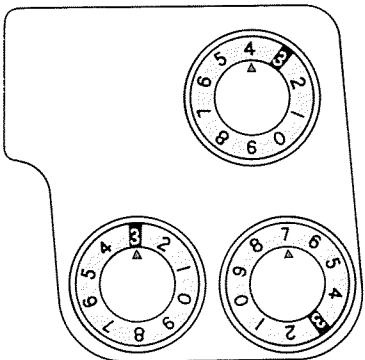
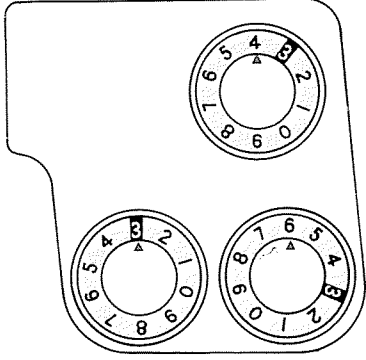
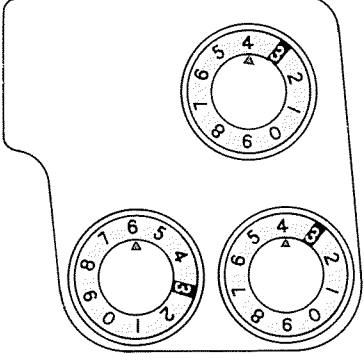
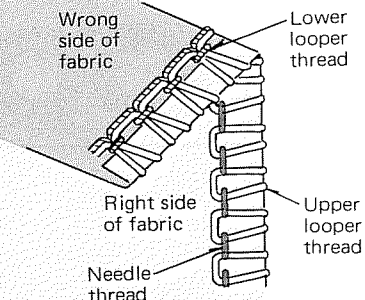
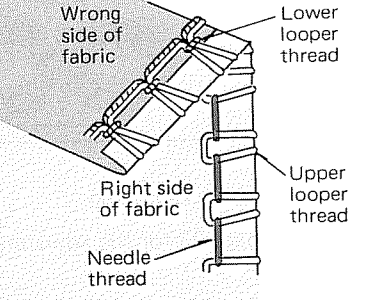
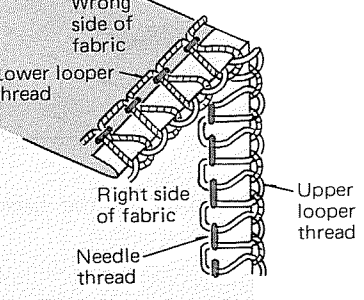
Fabric		Rolled Hemming	Picot Edging	Narrow Hemming
Lightweight fabric such as organdy, crepe de chine, lawn and georgette	Needle thread	Long fiber polyester thread No. 80 ~ 100		
	Upper and lower looper threads	Woolly nylon, Woolly polyester	Synthetic : 60 ~ 100, Silk : No. 50 ~ 100	Woolly nylon, Woolly polyester
	Needle	HA-1 SP No. 11		
	Standard setting of tension dials			
Correct thread tension				

Adjusting Thread Tension

1. Set the tension dials as shown on page 31.
2. Sew and check the tensions.

— For better result —

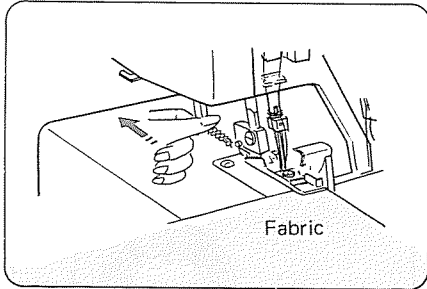

Rolled Hemming

Pull the end of thread chain to the back lightly in the beginning and end of sewing.

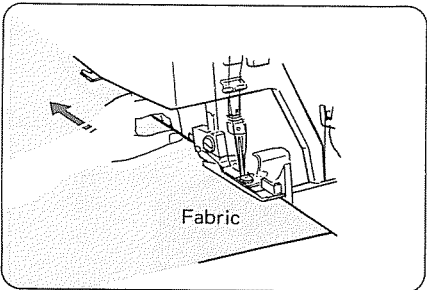

Picot Edging

Pull the fabric lightly to the back while sewing.

How to Adjust the Thread Tension

• For Rolled Hemming and Picot Edging

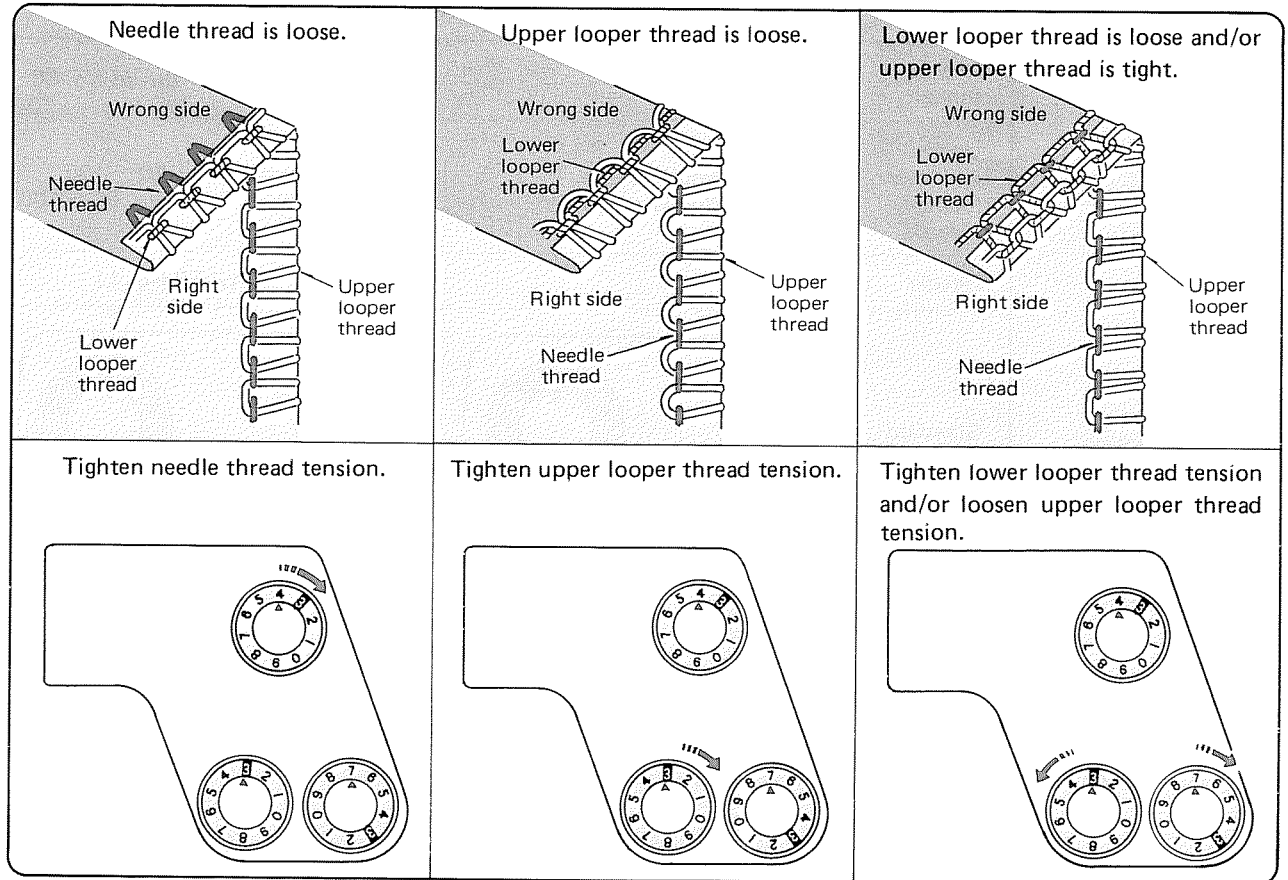

• For Narrow Hemming

Refer to page 23 for the adjustment.

DECORATIVE OVEREDGING

Thread, Fabric, Range of the Tension and Machine Setting

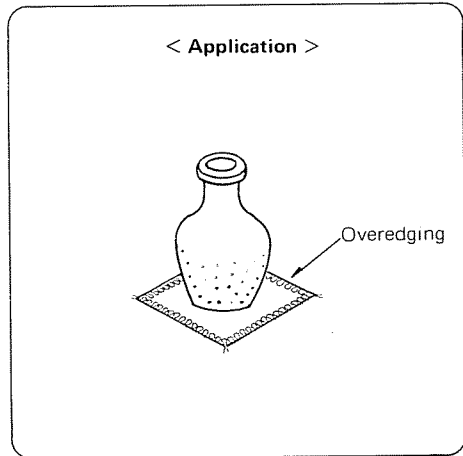

Fabric	Thread	Standard Setting
Medium to Heavy Fabric	Needle thread Synthetic : No. 60 ~ 80 Silk : No. 50 ~ 80	
	Upper looper thread Buttonhole twist Light weight wool yarn	
	Lower looper thread Synthetic : No. 60 ~ 80 Silk : No. 50 ~ 80	

Machine Setting	Stitch length	3 ~ 4 mm
	Needle plate	Regular needle plate.
	Needle	HA-1 SP No. 14

- * Refer to page 19 for the correct tension.
- * To adjust the thread tension balance, set the tension dials as shown above first, then refer to page 20.
- * For the best result, pull the thread chain to the back lightly at the beginning and end of sewing.
- * Remove the needle on either side for three thread decorative overedging.

PIN TUCKING

Fabric, Thread and Machine Setting

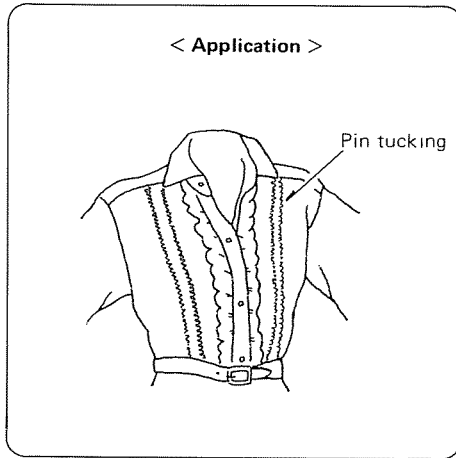

Fabric	Thread	
Light to Medium Fabric	Needle thread on the right	Synthetic : No. 60 ~ 80 Silk : No. 50 ~ 80
	Upper and lower looper threads	Synthetic : No. 60 ~ 100 Silk : No. 50 ~ 100

Machine Setting	Stitch length	2 ~ 3 mm
	Needle plate	Regular needle plate
	Needle	HA-1 SP No. 11 or 14

* Refer to pages 22 and 23 for thread tension balance adjustment.

Sewing

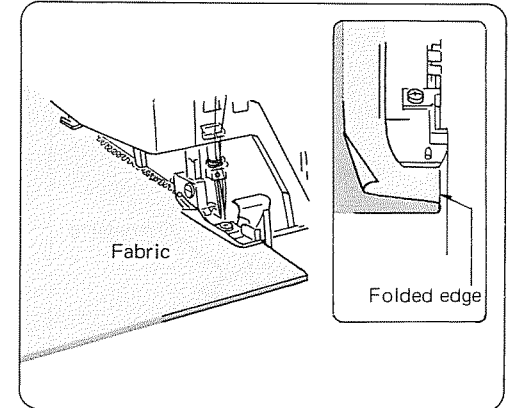

Remove the needle on the left hand side.
Deactivate the upper knife. (Refer to page 26.)

Sew the folded edge while guiding along the right side edge of lower knife.

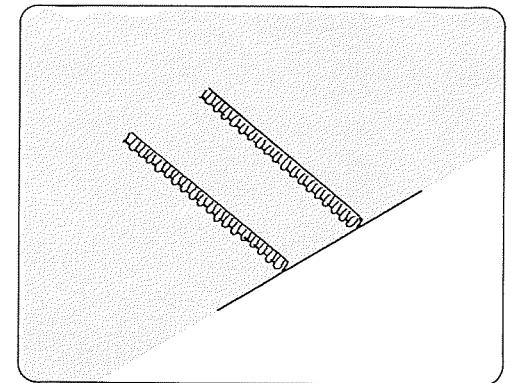

Press the pin tucks to one side.

* Activate the upper knife. (Refer to page 27.)

Replacing the Upper Knife

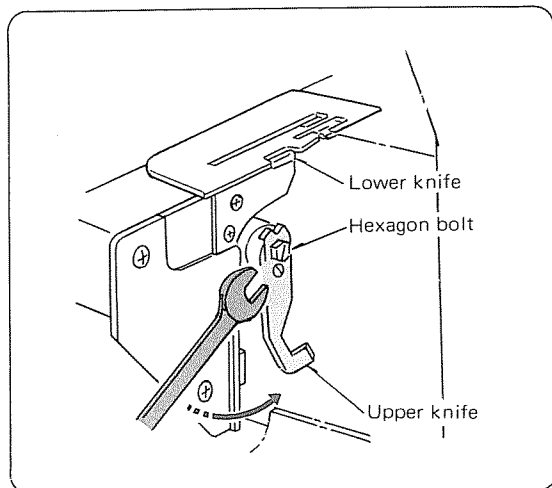

To Remove:

- ① Disconnect the machine from the power supply.
- ② Open the looper and side covers.
- ③ Deactivate the upper knife.
(Refer to page 26.)
- ④ Remove the hexagon bolt, and remove the upper knife.

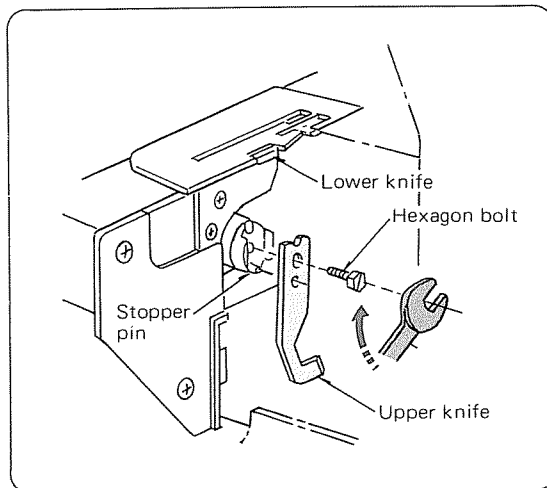

To Attach:

- ① Insert new upper knife into the groove of knife holder and stopper pin, then tighten the hexagon bolt slightly.

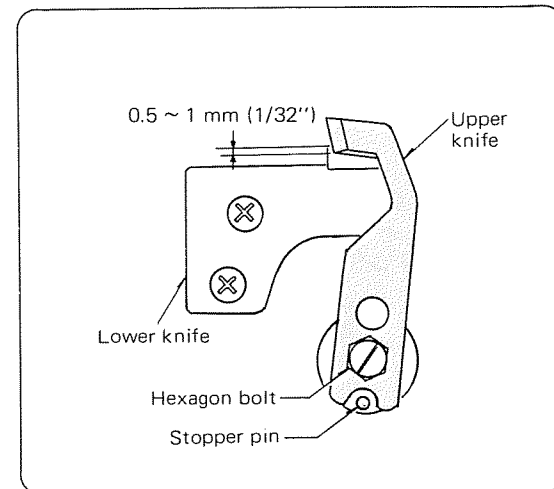

- ② Turn the upper knife holder to cutting position.
- ③ Turn the balance wheel toward you until the upper knife comes to its lowest position. Loosen the hexagon bolt, and adjust the position of upper knife so that the edge of the upper knife overlaps 0.5 to 1 mm (1/32'') from the edge of lower knife as shown above. Then tighten the hexagon bolt firmly.
- ④ Close the looper and side covers.

* The lower knife will last over one year in normal use. However, if you run over a pin or a hard object, it may be required to replace both upper and lower knives at the same time.

Cleaning Upper Knife Area

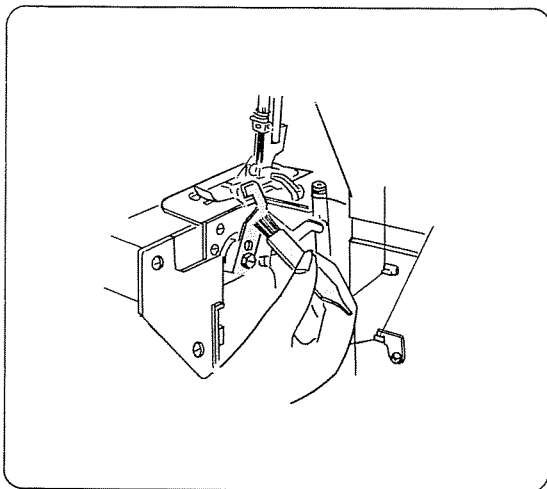

Open the looper cover.

Remove the waste chips to the front with a lint brush.

Cleaning the Feed Dog

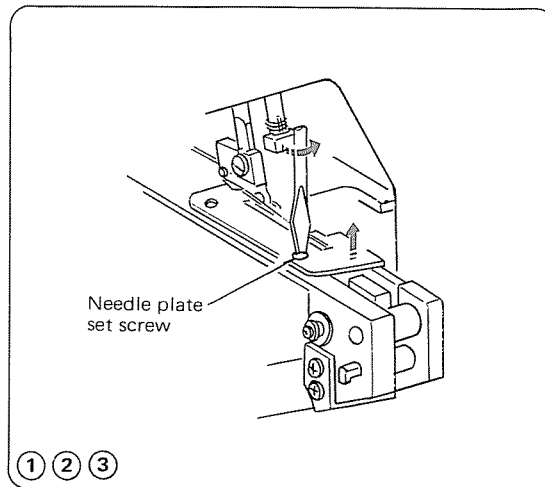

① Open the looper and side covers.

② Remove the needles and presser foot.

③ Remove the needle plate set screw, and remove the needle plate.

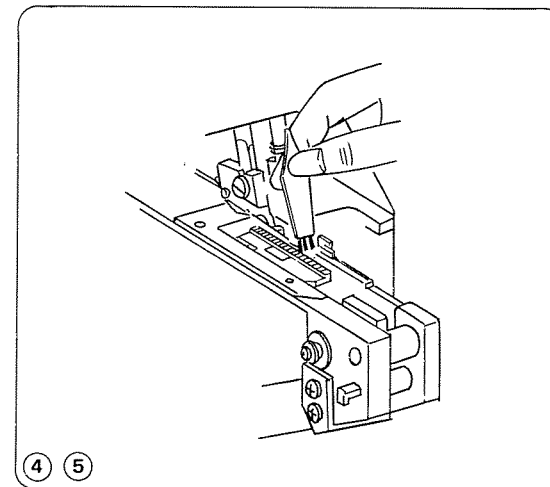

④ Push the lint around the feed dog to the front by using a lint brush.

⑤ Attach needle plate, presser foot and needles. Close the looper and side covers.

* Disconnect the machine from the power supply.

* You may use vacuum cleaner to clean the upper knife area or feed dog.

Replacing the Light Bulb

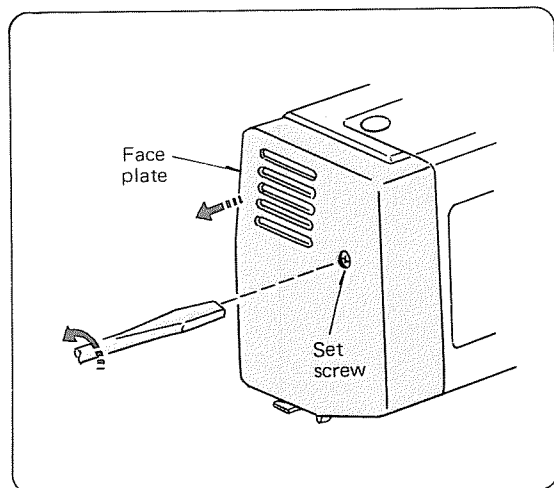

- ① Disconnect the machine from the power supply.
Remove the face plate set screw, and remove the face plate.

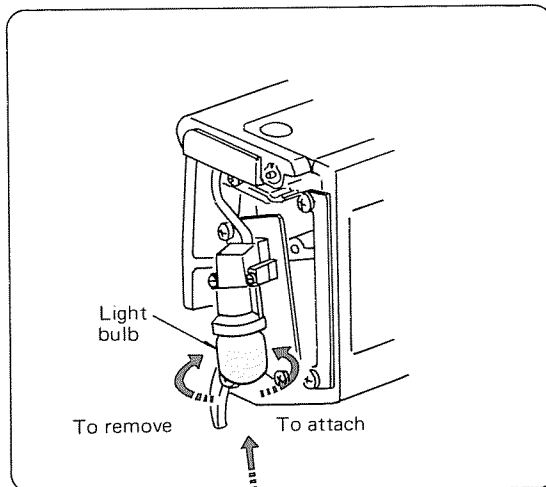

- ② **To Remove:**
Screw-on type Turn to the left.
Bayonet type Push and twist to the left.

To put on:

- Screw-on type Turn to the right.
Bayonet type Push and twist to the right.

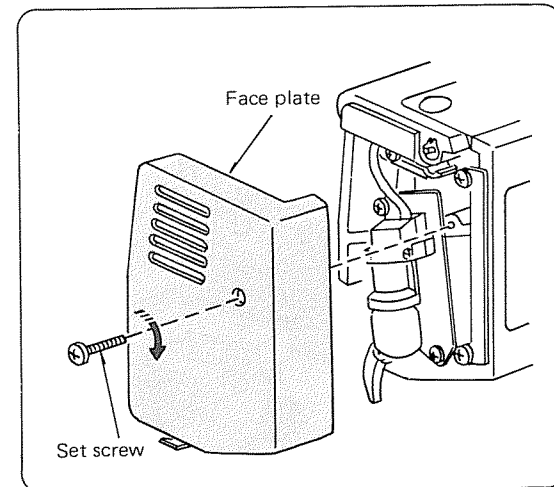

- ③ Attach the face plate, and tighten the face plate set screw.

For your safety:

- * The machine is designed to use a 15 WATT MAXIMUM LIGHT BULB.

Oiling the Machine

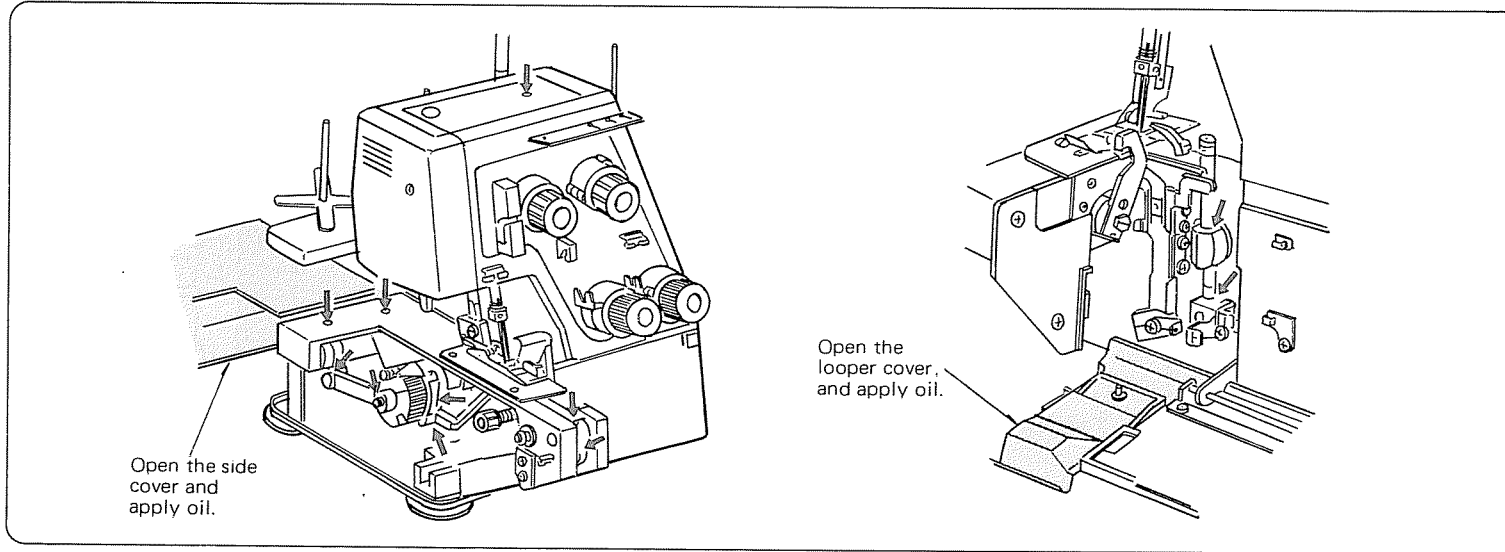

Apply a few drops of fine quality sewing machine oil to the parts indicated with arrows.

It is recommended to apply oil once a week in normal use, once in ten hours in continuous use.

Trouble Shooting

Condition	Cause	Reference
The fabric is not being fed smoothly.	<ol style="list-style-type: none"> 1. The feed dog is packed with lint. 2. The presser foot has been raised. 	<p>See page 36. Lower the presser foot.</p>
The needle breaks.	<ol style="list-style-type: none"> 1. The needle is incorrectly inserted. 2. The needle is bent or blunt. 3. The fabric is forcedly pulled. 	<p>See page 26. See page 26. Pull the fabric lightly.</p>
The thread breaks.	<ol style="list-style-type: none"> 1. The machine is not correctly threaded. 2. The needle or looper thread tension is too tight. 3. The needle is incorrectly inserted. 4. The needle is bent or blunt. 	<p>See pages 7 ~ 15. See pages 19 ~ 23 and 31 ~ 33. See page 26. See page 26.</p>
Skipped stitches	<ol style="list-style-type: none"> 1. The needle is not correctly threaded. 2. The needle is bent or blunt. 3. The machine is not correctly threaded. 	<p>See page 26. See page 26. See pages 7 ~ 15.</p>
The seam is not sewn neatly.	<ol style="list-style-type: none"> 1. The needle and/or looper thread tensions are not correctly adjusted. 2. The machine is not correctly threaded. 3. The needle and/or the thread are not suitable for the fabric being sewn. 4. The thread is not between the tension discs. 	<p>See pages 19 ~ 23 and 31 ~ 33. See pages 7 ~ 15. See pages 29, 31, 33 and 34. See pages 9, 11 and 13.</p>
Seam puckering.	<ol style="list-style-type: none"> 1. The needle or looper thread tension is too tight. 2. The machine is not correctly threaded. 3. The needle plate is not suitable for the use. 	<p>See pages 19 ~ 23, 31 and 32. See pages 7 ~ 15. See page 27.</p>
The machine does not operate.	<ol style="list-style-type: none"> 1. The machine has not been plugged in firmly. 2. The power switch is turned off. 	<p>See page 4. See page 4.</p>
The fabric is not cut neatly.	<ol style="list-style-type: none"> 1. The position of the upper knife is not adjusted properly. 2. The upper knife is dull. 	<p>See page 35. Replace the upper knife. (See page 35.)</p>

