

OWNER'S MANUAL

SEARS

Kenmore

SEWING MACHINE

**MODEL 1340 / 1345 / 1350 / 1355 / 1358
1561 / 1595**

TABLE OF CONTENTS

1. KNOWING YOUR SEWING MACHINE

Machine identification	2 - 3
Parts list.....	4 - 5
Setting up your machine	6
Spool pins, Foot control, Light/power switch	
Installing extension table	6
Winding bobbin	7
Removing bobbin case from shuttle	8
Inserting bobbin into bobbin case	9
Inserting bobbin case into shuttle	9
Threading top thread.....	10
Picking up bobbin thread.....	11

CONTROLS

Thread tension control.....	12
Stitch selector, Stitch length control	13
Reverse stitch control, Pressure regulator	14
Seam guides, Presser foot lever, Feed dog control.....	15

ACCESSORIES

Needles.....	16
Placement of needle	16
Needle, thread and fabric chart	17
Feed cover plate, Presser feet	18

CARING FOR THE MACHINE

Cleaning feed dogs and shuttle	19
Oiling	20 - 21
Changing light bulb.....	21

CHECKING PERFORMANCE PROBLEMS

2. STARTING TO SEW

Straight stitching	25 - 27
Fastening a seam, Turning a square corner, Removing fabric, Top stitching, Darning, Temporary sewing by machine, Zipper application-Cording	
Zigzag stitching.....	28 - 30
Checking thread tension, Overcasting, Satin stitching, Bar tacking, Appliqueing, Button sewing	
Blind Hemming	31
Mending and overcast stitching (three-step zigzag)	32
Shell stitching.....	33
Box stitch	34
Stretch stitches	35 - 38
Adjusting stitch length, Straight stretch stitch, Rick-rack stretch, Smocking stretch, Overcast stretch, Serging (or pine leaf) stretch, Elastic stretch	
Where to use which stretch stitch: A check-chart	39
Buttonhole making	40 - 47
Free-arm sewing.....	48

1. KNOWING YOUR SEWING MACHINE

MACHINE IDENTIFICATION

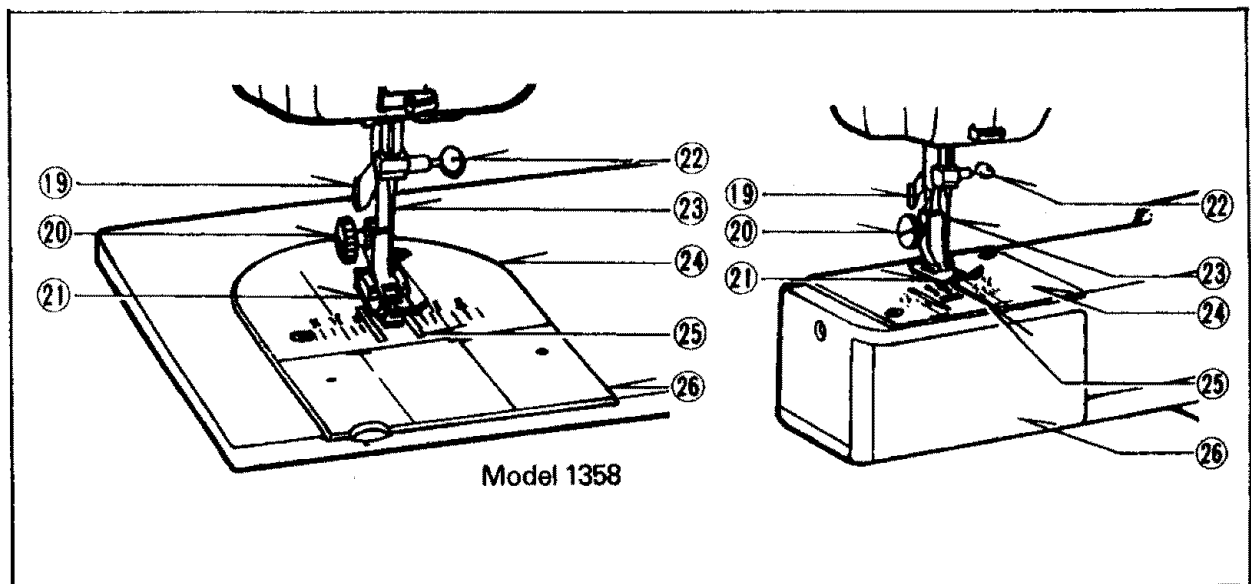
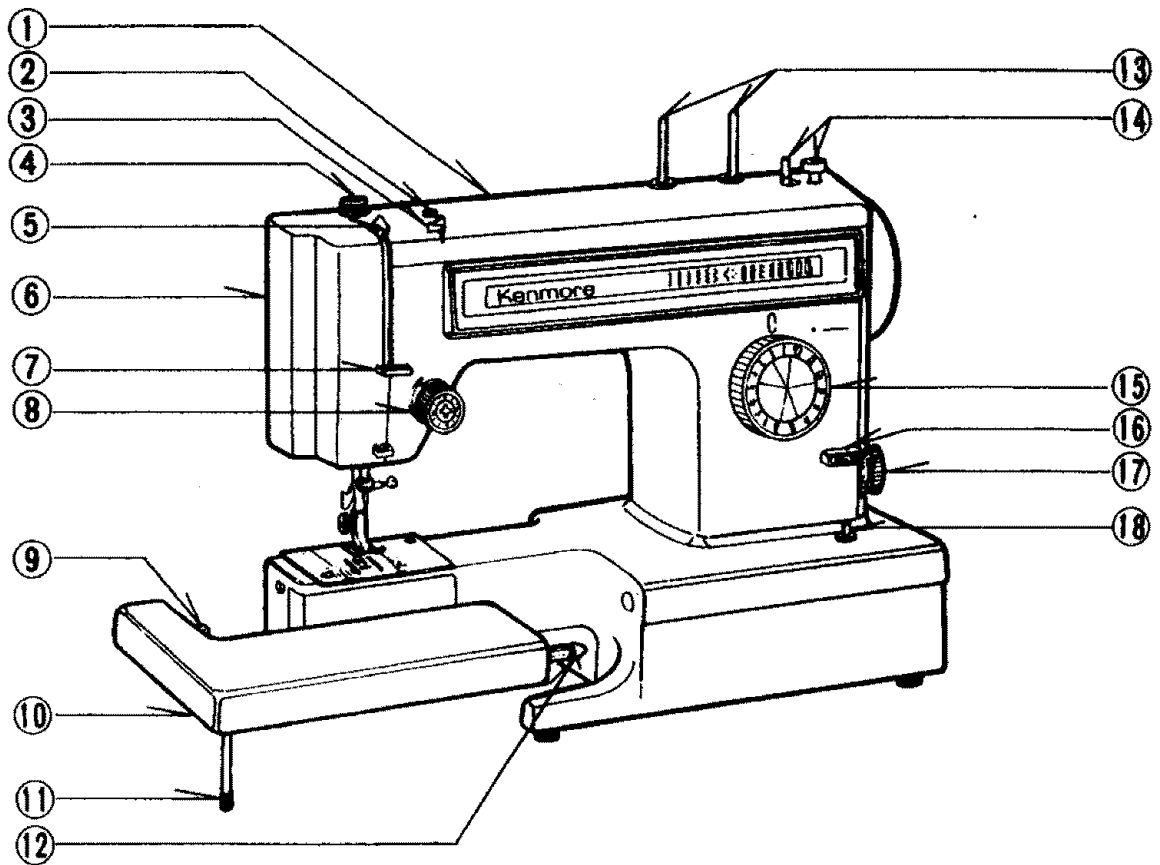

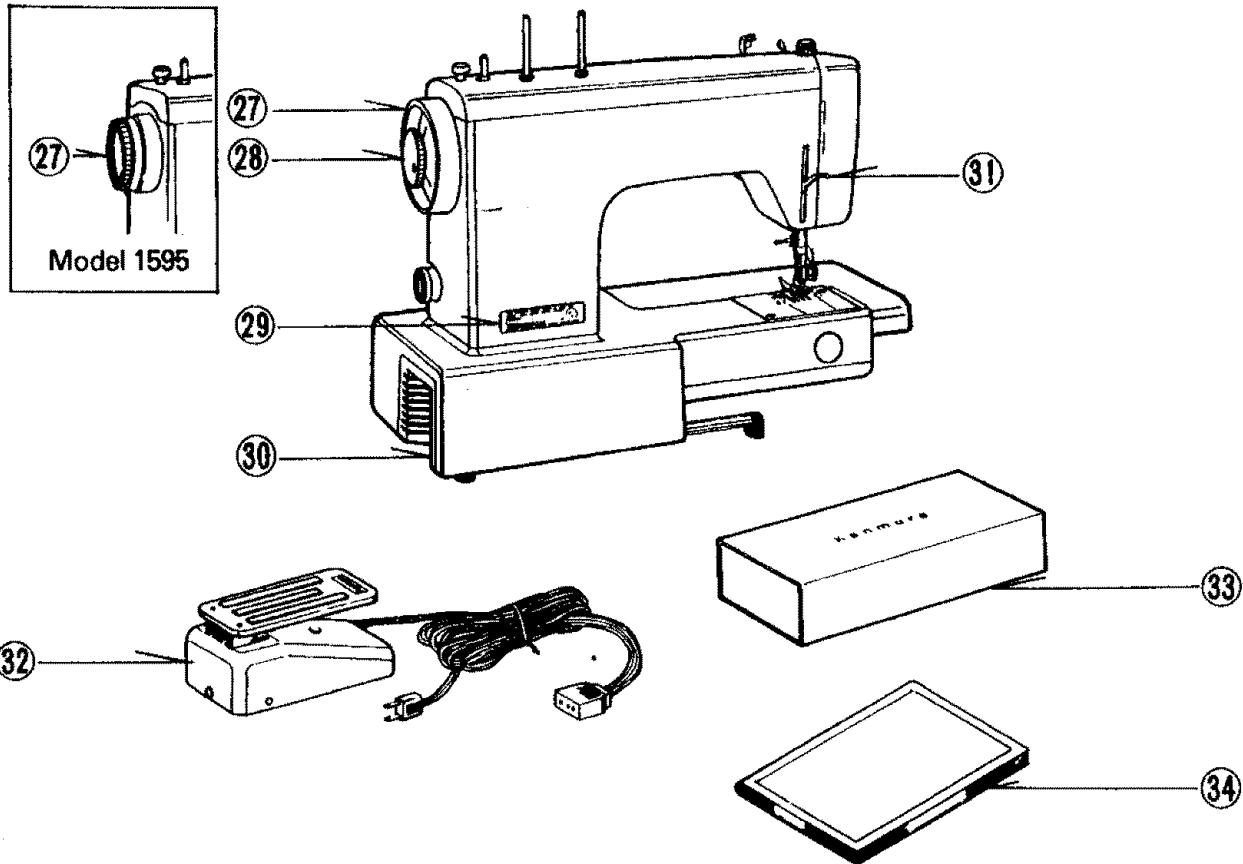

- | | |
|-------------------------------|------------------------------|
| 1. Top cover | 18. Light/power switch |
| 2. Bobbin winder tension disc | 19. Thread cutter |
| 3. Thread guide | 20. Presser foot thumb screw |
| 4. Pressure regulator | 21. Presser foot |
| 5. Take-up lever | 22. Needle clamp screw |
| 6. Face cover | 23. Needle |
| 7. Face cover thread guide | 24. Needle plate |
| 8. Top thread tension control | 25. Feed dogs |
| 9. Guide pin | 26. Shuttle cover |
| 10. Extension table | 27. Hand wheel |
| 11. Support leg | 28. Clutch knob |
| 12. Guide pin | 29. Nomenclature plate |
| 13. Spool pins | 30. Electric cord receptacle |
| 14. Bobbin winder | 31. Presser foot lever |
| 15. Stitch selector | 32. Foot control |
| 16. Reverse stitch lever | 33. Accessory box |
| 17. Stitch length dial | 34. Owner's manual |

PARTS LIST

PARTS AND ACCESSORIES PROVIDED WITH MACHINE

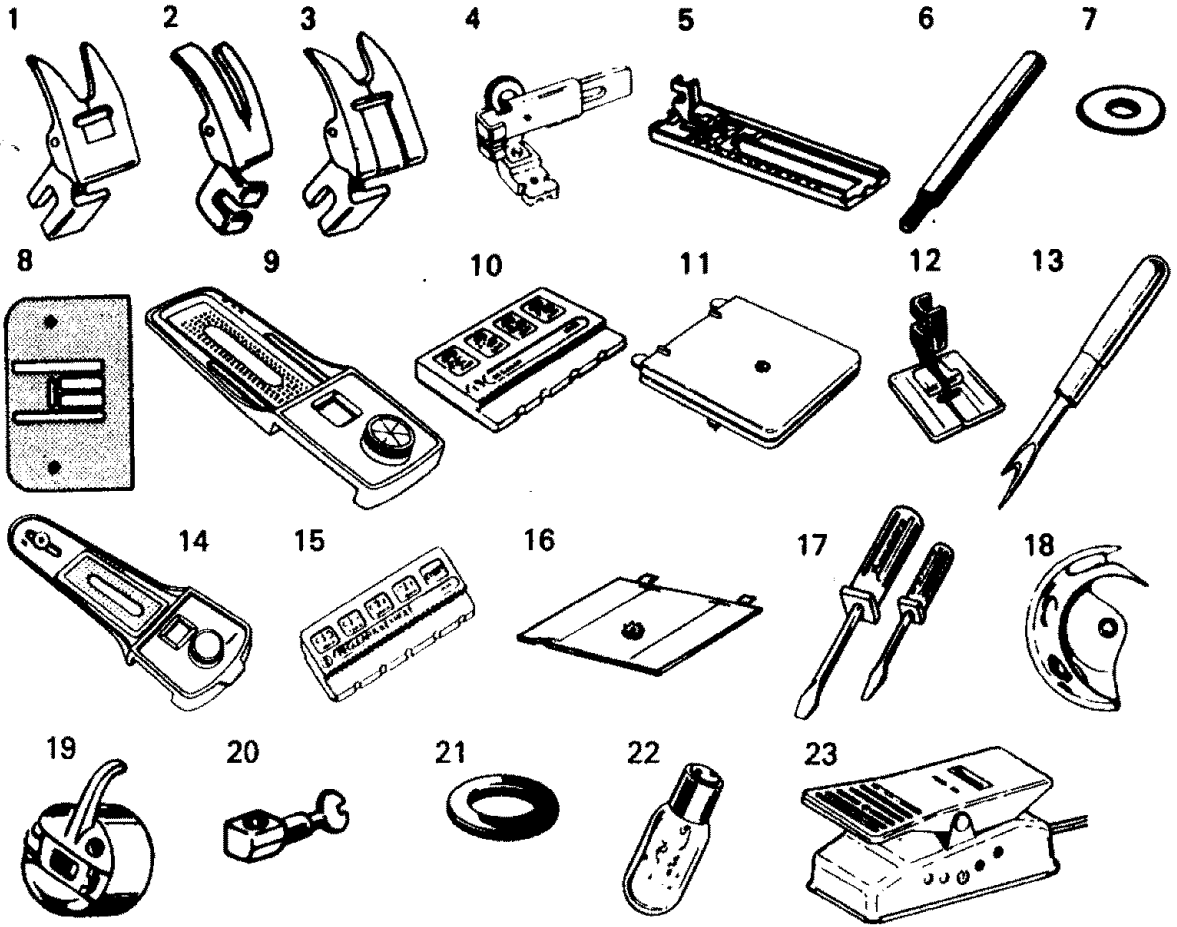

OPTIONAL ACCESSORIES

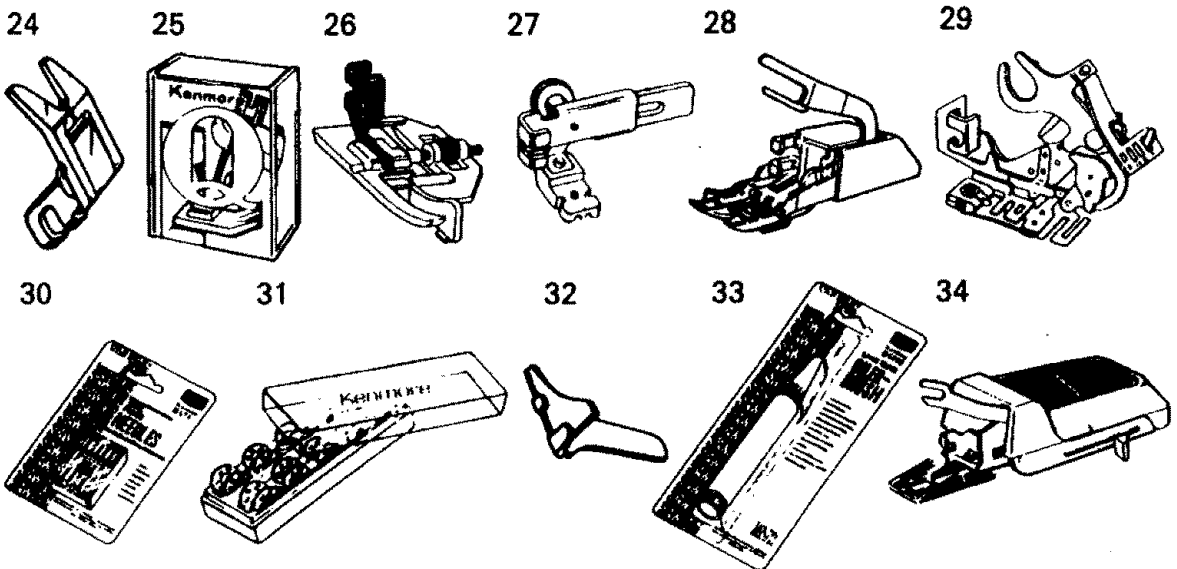

PARTS LIST (Use only genuine Kenmore replacement parts and accessories.)

All parts listed herein may be ordered from any Sears, Roebuck and Co. store or service center.

WHEN ORDERING REPAIR PARTS, ALWAYS GIVE THE FOLLOWING INFORMATION:

1. PART NUMBER
2. PART DESCRIPTION

3. MODEL NUMBER shown on the nomenclature plate. (See page 3 for location.)

4. NAME OF ITEM

If the parts you need are not stocked locally, your order will be electronically transmitted to a Sears Repair Parts Distribution Center for expedited handling.

Ref. No.	Part No.	Description	Ref. No.	Part No.	Description
1	40390	Zigzag presser foot	21	1939	Bobbin winder rubber ring
2	6873	Straight stitch foot	22	6797	Light bulb
3	6870	Satin stitch foot	23	6811	Foot control
4	6757	Zipper foot	24	6782	"Q FOOT"
5	47149	Buttonhole guide foot	25	6882	"Q SET"
6	8286	Thread spool pin	26	6885	Blind hem foot
7	2273	Nylon disc	27	6792	Hinged zipper foot
8	45846	Feed cover plate	28	6887	Even feed foot
9	58232	Buttonhole guide plate	29	6891	Ruffler pleater
10	45195	Buttonhole template No. 1	30	6550	No. 9 needles
	45196	Buttonhole template No. 2		6551	No. 11 needles
	45197	Buttonhole template No. 3		6552	No. 14 needles
11	58700	Buttonhole adapter		6553	No. 16 needles
12	42679	Buttonhole foot		6554	No. 18 needles
13	6830	Buttonhole opener		6746	"Q NEEDLE"
14	55824	Buttonhole guide plate for 1358	31	6862	10 bobbins in case
15	35346	Buttonhole template No. 1 for 1358	32	6864	Needle threader
	35347	Buttonhole template No. 2 for 1358	33	6889	Oiler-brush combination
16	56183	Buttonhole cover plate for 1358	34	6736	Automatic buttonholer makes 3 styles in 10 sizes
17	55501	Large screw driver	—	6840	Accessory set (not shown) for heming, edgestitching, binding, gathering, quilting, attaching braid, lace, zippers incl. "Q SET".
	55500	Small screw driver			
18	47	Shuttle			
19	6510	Bobbin case			
20	36353	Needle clamp with screw			

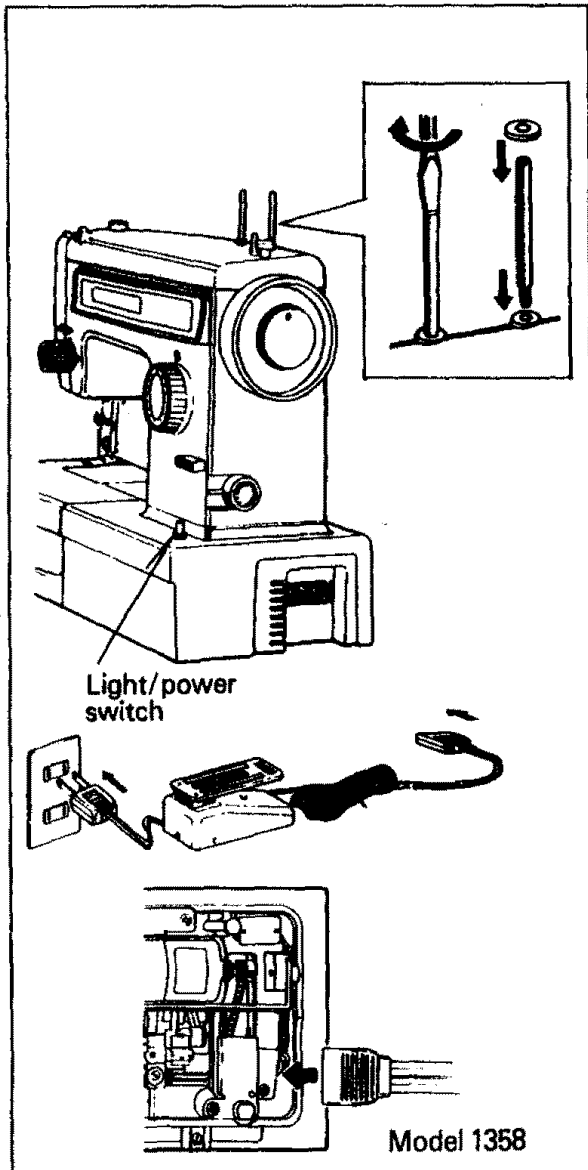

SETTING UP YOUR MACHINE

1. Install your Kenmore sewing machine in a Kenmore cabinet, case or set the machine on a sturdy flat surface.
2. Your Kenmore sewing machine has been thoroughly oiled at the factory. Be sure to wipe off the needle plate area, bed plate and bobbin case carefully before sewing a garment. It is wise to practice on a scrap of fabric so any surplus oil is absorbed.
3. **SPOOL PINS**
You'll find spool pins and nylon discs packed in the accessory box. Using a screwdriver, attach spool pins securely on the top cover and position nylon discs over the spool pins as indicated.
4. **FOOT CONTROL**
Plug foot control into machine receptacle. Then connect cord into any 110-120 volt A. C. wall outlet.
5. **LIGHT/POWER SWITCH**
Your machine **will not operate** unless the light/power switch is turned on. Turning on the power automatically illuminates the whole stitching area. If you're interrupted or stop sewing, turn off the light/power switch.

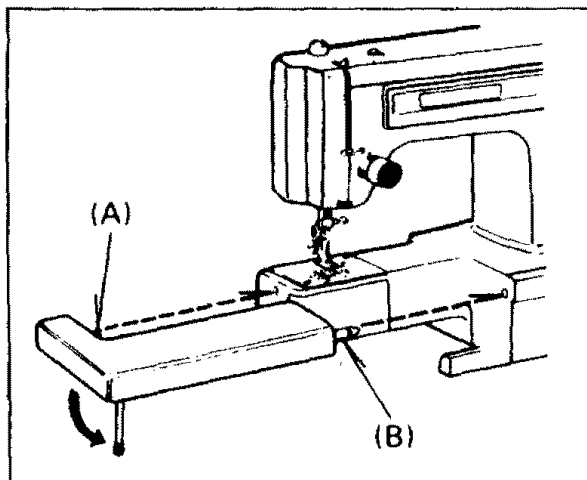

INSTALLING EXTENSION TABLE

For all flat-bed sewing use the extension table provided with the machine. To install the extension table, simply slide the table along the free arm until the two pins (A) and (B) enter fitting holes in the machine. Lower the support leg.

To utilize free-arm feature for sewing tubular material, remove the extension table from the machine by pulling it to the left.

WINDING BOBBIN

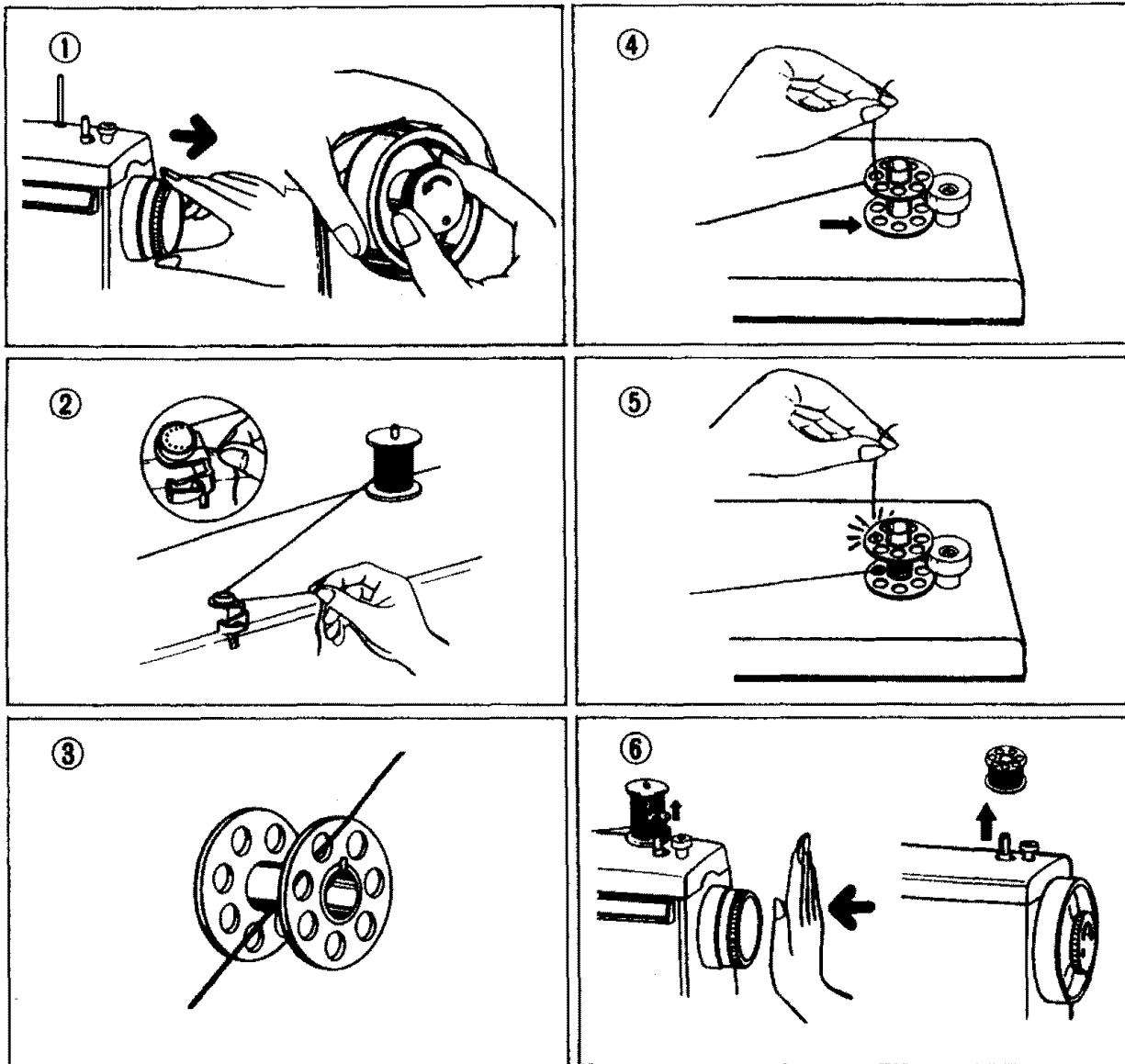

1. Release clutch by pulling hand wheel or turning clutch knob toward you.
2. Draw thread from spool through bobbin winder tension disc as shown.
3. Pull end of thread through hole in bobbin as shown.
4. Push bobbin winder shaft to far left position, if it is not already there. Place bobbin onto shaft with end of thread

5. Start machine. The thread that is held will snap. Bobbin will cease turning when completely filled. Push shaft to left to remove bobbin.
6. Push in hand wheel or tighten clutch knob and remove bobbin.

REMOVING BOBBIN CASE FROM SHUTTLE

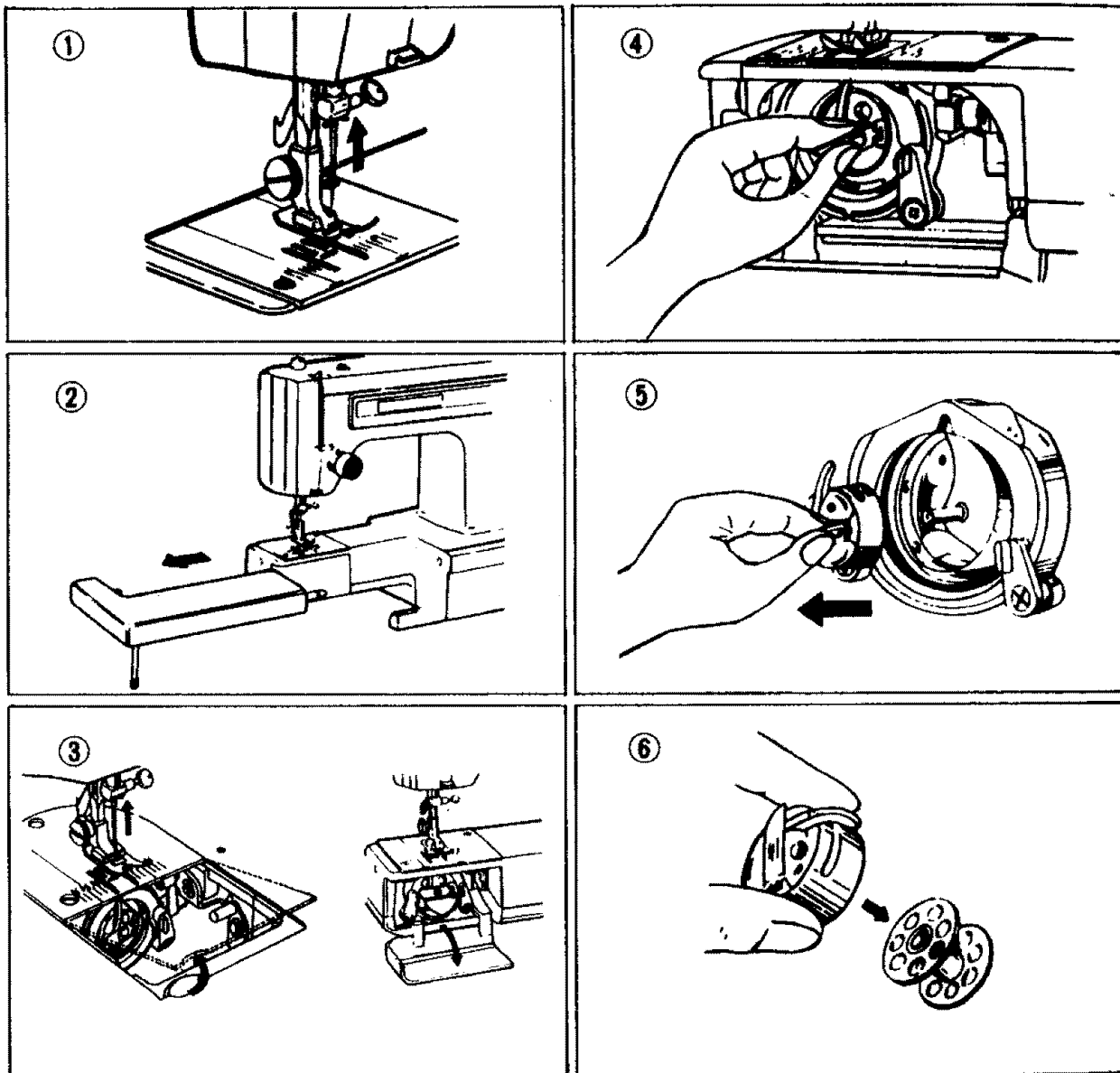

1. Raise needle to its highest position rotating hand wheel toward you.
2. Remove the extension table from machine by pulling it to the left.
3. Open shuttle cover.
4. To remove bobbin case from shuttle, pull open latch of bobbin case.
5. Pull bobbin case straight out of shuttle.
6. Release the latch and bobbin will come out from bobbin case.

INSERTING BOBBIN INTO BOBBIN CASE

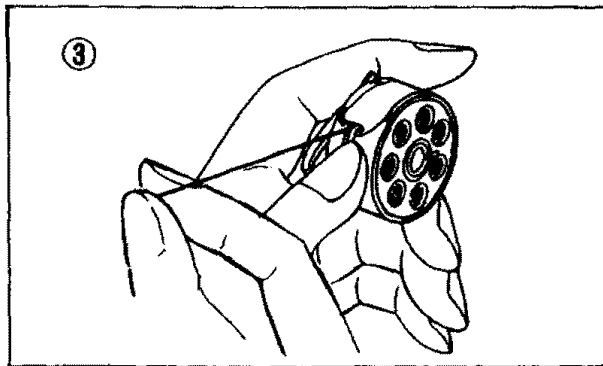
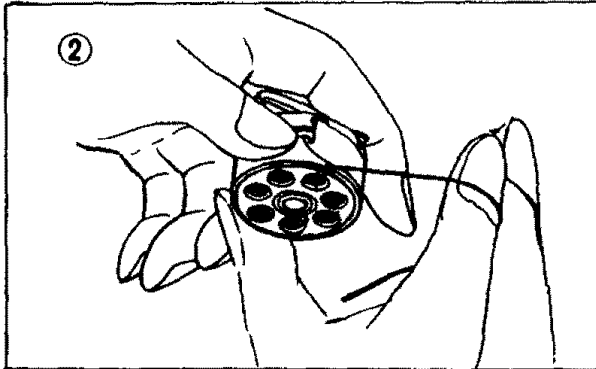
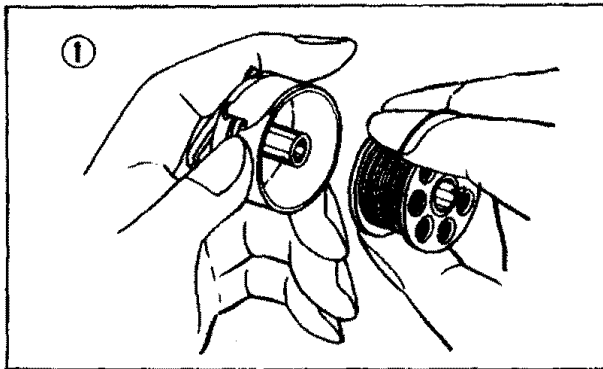

1. With the bobbin case in your left hand, place the bobbin into it with the thread running clockwise.
2. Feed the thread through the slot in the case.
3. Pull the thread under the tension plate.
4. Draw 3 to 4 inches of thread from bobbin.

INSERTING BOBBIN CASE INTO SHUTTLE

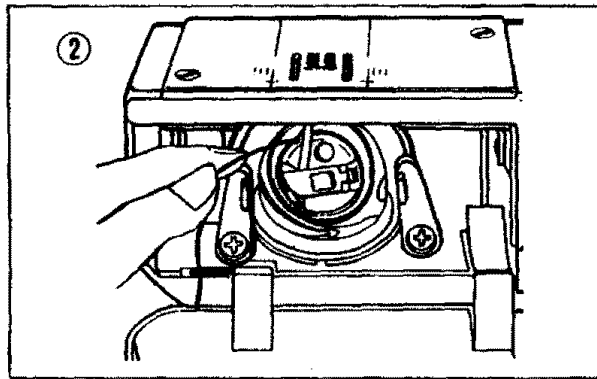
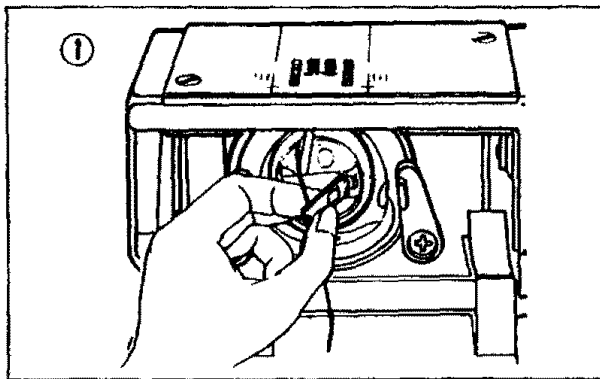

1. With locating pin straight up, hold the latch open, and slide the bobbin case on to the center spindle of the shuttle.
2. Make sure the locating pin fits into the locating groove at the top of the shuttle. Release the latch to lock the bobbin case into place.

THREADING TOP THREAD

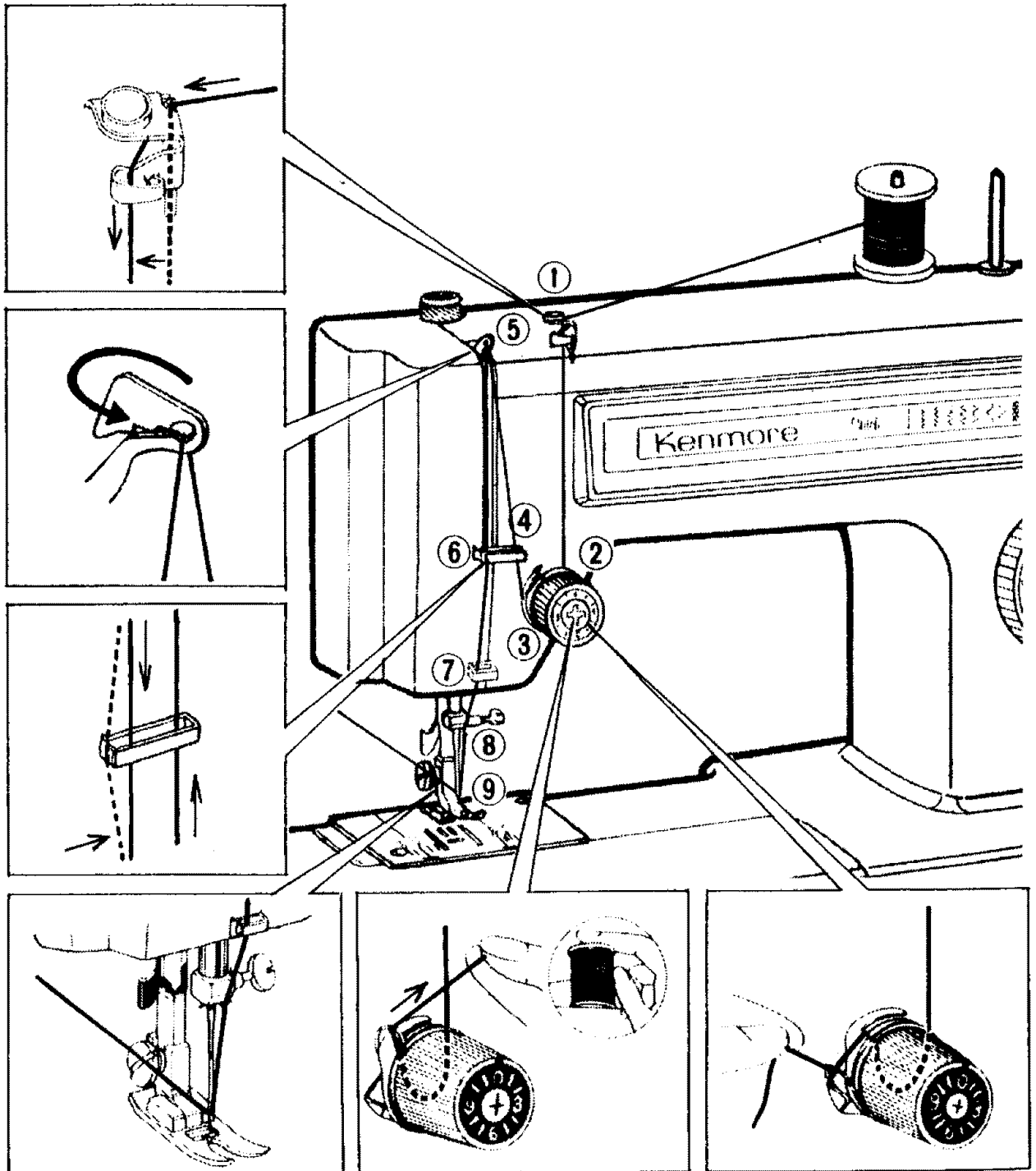

1. Raise thread take-up lever to its highest position by turning hand wheel toward you. Raise presser foot lever. Place thread spool on spool pin. Draw thread through thread guide 1. Holding spool stationary with right hand, pull thread through the tension discs. Pull the end of the thread taut with the left hand.

2. This will pull the spring wire up and past the end of the hook. The thread will then slip into the hook when the spring is released.
3. Draw thread up through thread guide 4 take-up lever 5 and down through lower thread guides 6, 7, 8 to needle.

3. The needle must be threaded from front to rear. Draw 3 to 4 inches of thread through the eye of needle.

PICKING UP BOBBIN THREAD

1. Raise presser foot lever. Hold needle thread loosely in left hand and rotate handwheel toward you one complete turn.

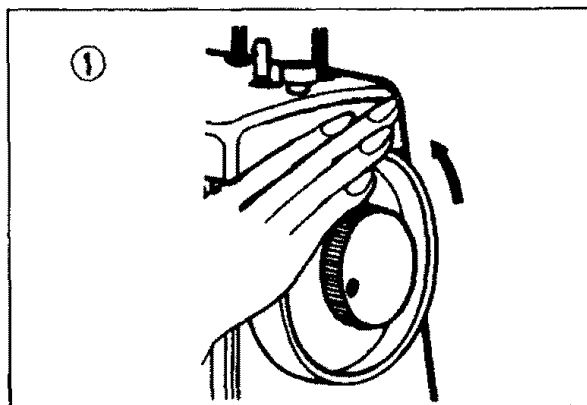

2. Bring bobbin thread up by pulling upper thread.

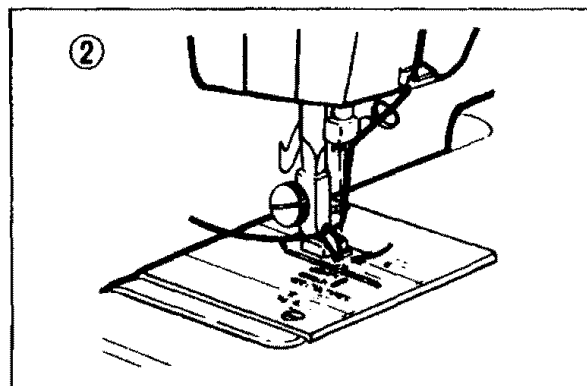

3. Pull both threads under and to the back of the presser foot, leaving 3 to 4 inches of thread clear.

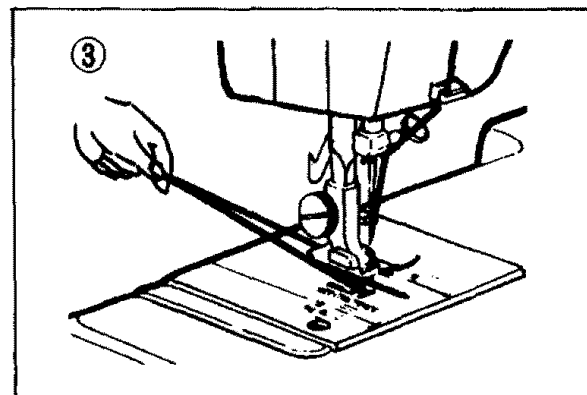

If you can not pick up bottom thread by following above steps, then check:

1. Is thread through needle ?
2. Is thread tangled around needle ?
3. Is there 3 to 4 inches of thread coming out of bobbin case ?
4. Is thread from bobbin case tangled ?

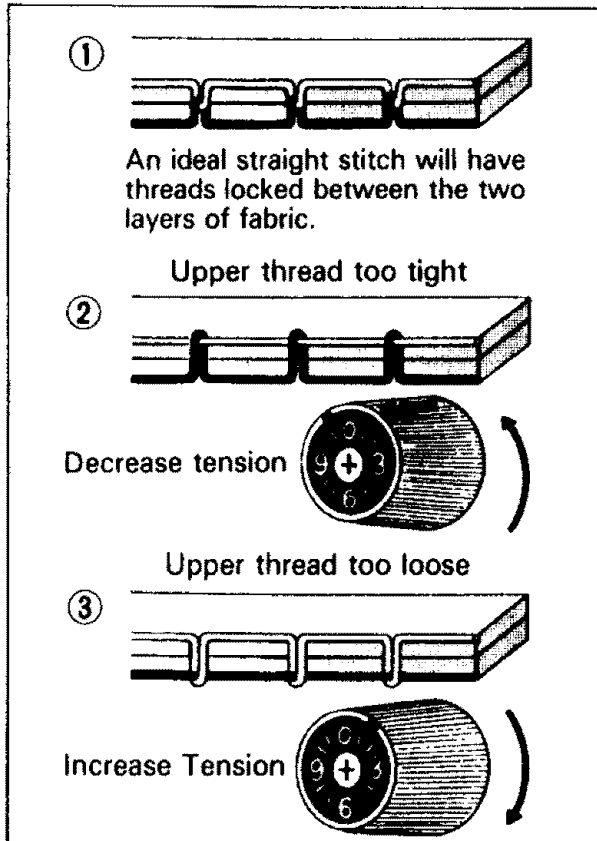

ADJUSTING TOP THREAD TENSION

Probably the most important control on your machine is this one that regulates your top thread tension.

There are many reasons for having to reset your tension. The best tension for one fabric may not be correct for another. The required tension depends upon the stiffness of the fabric, thickness of the fabric, numbers of layers of fabric being sewn, as well as the type of stitch you are making.

It is best to test the stitching on a scrap of the fabric you are using before starting to make a garment. Use the straight stitch function as shown at the right.

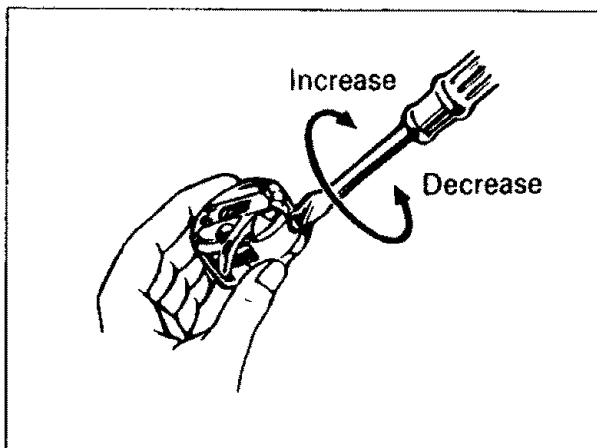

ADJUSTING BOBBIN THREAD TENSION

When stitching is unsatisfactory in figures 2 and 3 above, adjust the upper thread tension. LOWER THREAD TENSION REQUIRES ADJUSTMENT LESS FREQUENTLY THAN THE UPPER THREAD TENSION.

When stitch is satisfactory, as in Fig. 1 and seam is badly puckered, the cause may be tight tensions and both upper and lower may have to be adjusted.

When adjusting the tension on the bobbin case, make slight adjustments with a screwdriver.

STITCH SELECTOR

There are certain types of stitches that are used more often than others in your garment construction. Because of their frequent use, you will soon realize the convenience offered to you by this control. All of the stitches that

are made by this machine are illustrated on the stitch selector dial. You can obtain your desired stitch by simply turning the stitch selector dial.

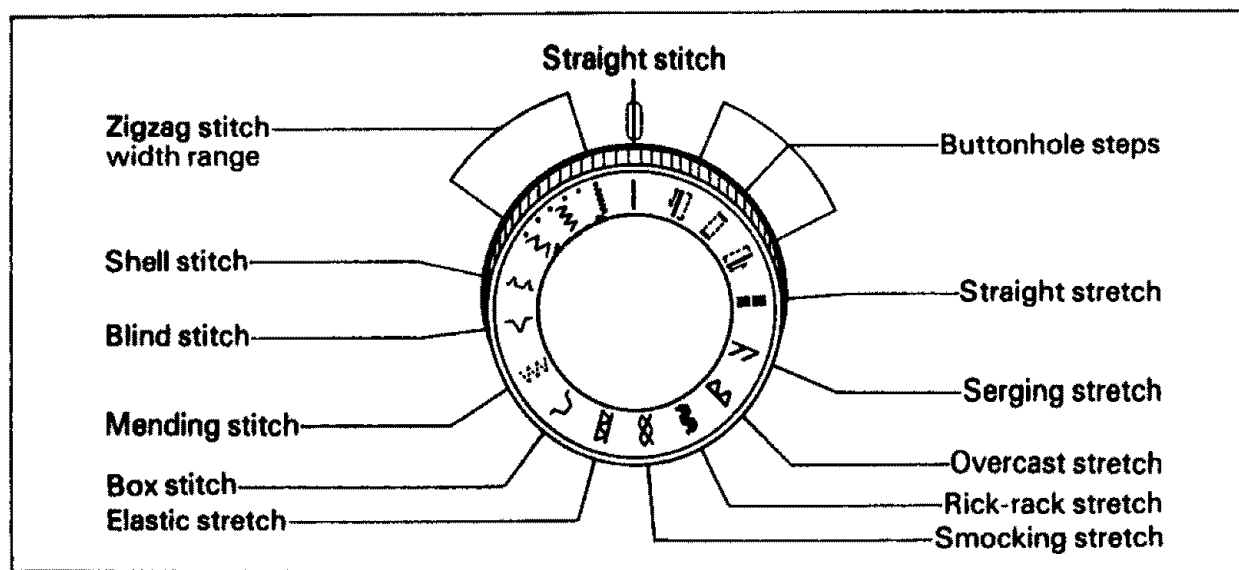

STITCH LENGTH CONTROL

1. Recommended stitch length settings are indicated in three colors and color-coded with stitch patterns on the selector.
2. Turn the knob toward you to lengthen a stitch and away from you to shorten.
3. Orange graduation indicates the approximate number of stitches per inch (6-8-12-24) of both straight and zigzag stitches.
4. Stitches per inch are printed on the end of the dial for your convenience.

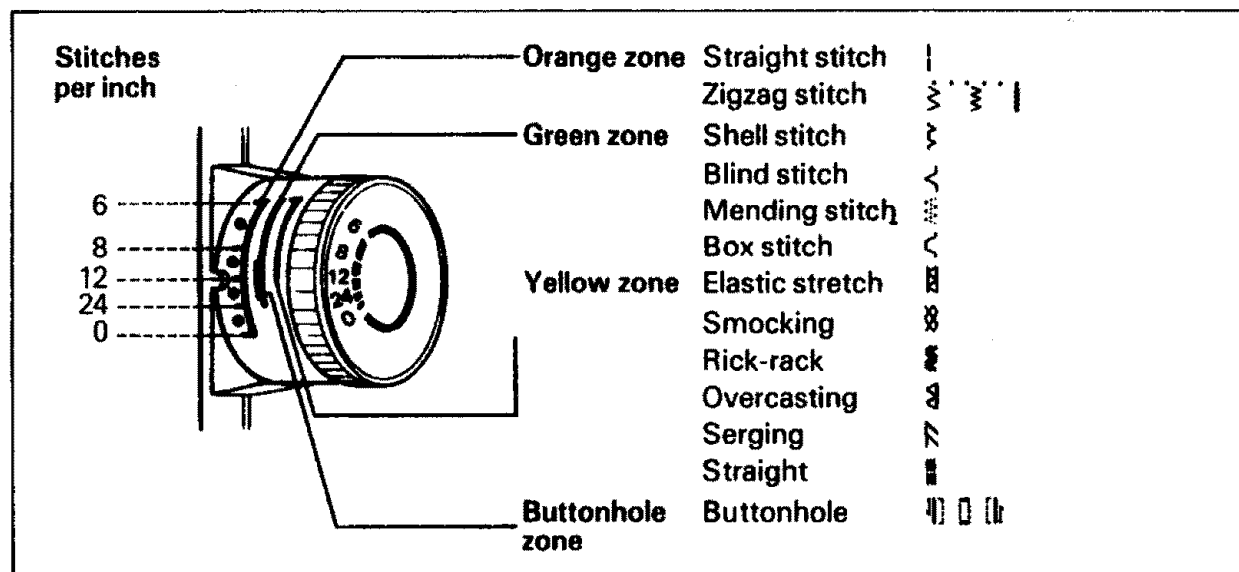

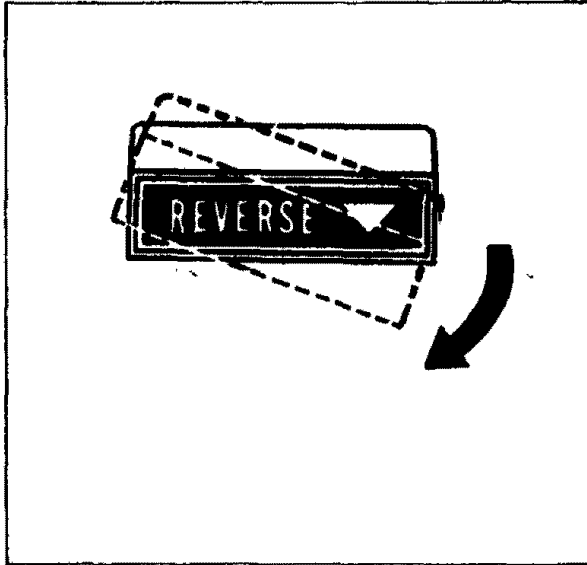

REVERSE STITCH CONTROL

It is best to begin and end seams with a few stitches taken in reverse. This is called back tacking. Back tacking fastens the ends of the seams firmly and prevents raveling.

When reverse stitching is needed, turn the control clockwise and hold there during sewing. The fabric will immediately start feeding backwards and seam will be fastened.

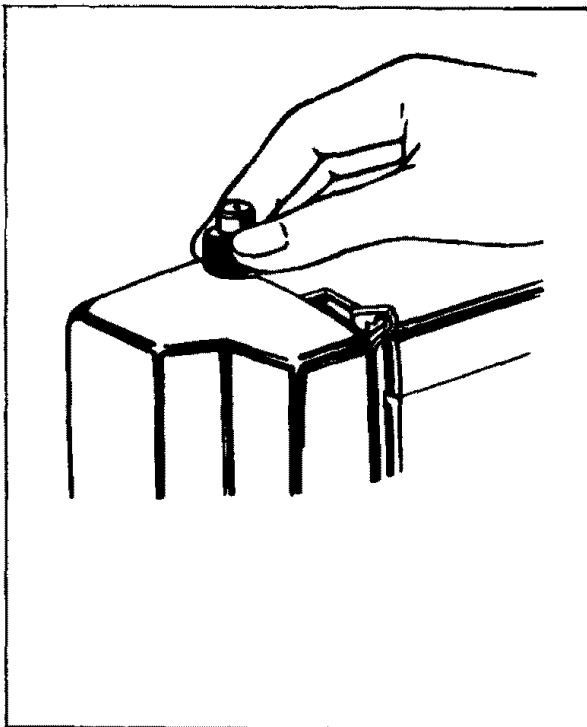

PRESSURE REGULATOR

Push down the outer ring of the pressure regulator. This will release the pressure on the presser foot. To increase the pressure, push down inner pin until a suitable pressure is obtained.

Insufficient pressure may cause poor feeding of the fabric, skipped stitches, or difficulty in guiding the fabric. If feed dogs or presser foot marks appear on the fabric, reduce the pressure.

For sewing of medium weight fabric, the inner pin should be pushed all the way down.

When sewing multiple thicknesses or heavy fabric, reduce the pressure with the pin $\frac{1}{2}$ way down.

Light weight fabrics need full pressure, unless feed dog marks are visible on fabric. Reduce slightly to eliminate marks, but retain good feeding.

SEAM GUIDES

Seam guides are printed on needle plate, at both sides of needle, to help you line up the fabric and keep it straight. The standard seam width is $5/8$ ". So these lines are emphasized, easy to follow.

Also the cross lines are "cornering guides" to help when turning a square corner $5/8$ " from the fabric edge. (For details on cornering, see page 25.)

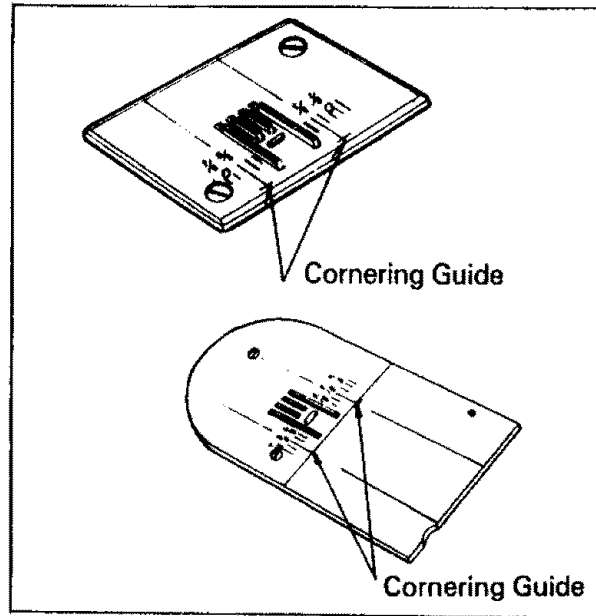

PRESSER FOOT LEVER

Presser foot lever has a two position lift. In order to place heavy fabric under the presser foot or to change the presser foot raise the presser foot lever to its maximum upward position as shown.

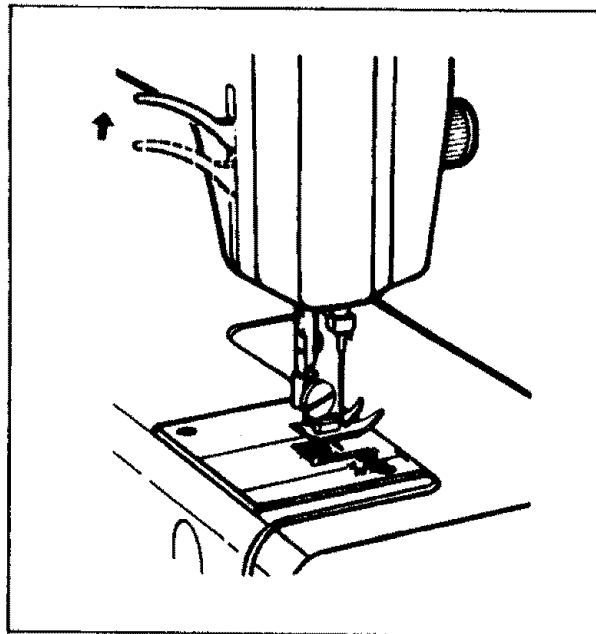

FEED DOG CONTROL (Model 1358)

The feed dog control is located on the right front of the machine bedplate. There are a few times when you want to control the feeding of the fabric yourself. When the control is turned to the left, the feed dogs drop and do not move the fabric.

For most of your sewing, turn knob to the right.

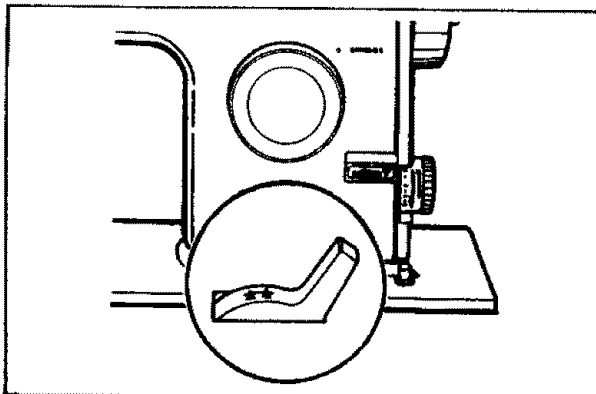

ACCESSORIES

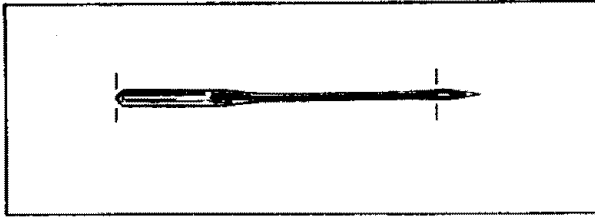

NEEDLES

Use KENMORE needles. The size of the needle should conform with the size of the thread and both should be suitable to the fabric. Kenmore needles are color-coded by size for your convenience (See chart on next page).

Never use a bent needle or one with a dull point.

If you do not have a Kenmore needle, please use this illustration to be sure your needle is the right size. Distance from top of needle to needlehole should be this exact length.

You will find among your accessories a "Q NEEDLE" with blue shank. This special needle is to be used when sewing knits and certain difficult synthetic fabrics. If you experience **skipped stitches** in any of your sewing, use "Q NEEDLE" and "Q FOOT".

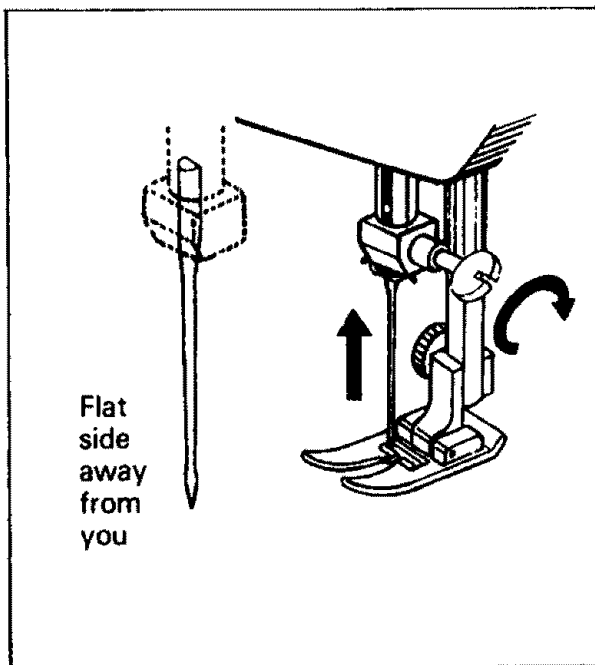

PLACEMENT OF NEEDLE

Raise needle bar to its highest position by turning the hand wheel toward you. Loosen the needle clamp screw. Holding the needle with the **flat side away from you**, slip the needle into the needle bar. When it is in as far as it will go, tighten the needle clamp screw with small screwdriver provided in the accessory box.

NEEDLE, THREAD AND FABRIC CHART

FABRIC	NEEDLE SIZE AND COLOR	THREAD SIZE	RECOMMENDED STITCH LENGTH SETTING
LIGHTWEIGHT: Batiste, Dimity, Chiffon, Silks, Synthetic Jerseys, Fine Lace, Organza, Crepe, Taffeta, Voile, Organdy	9 - BROWN or 11-ORANGE	Polyester Core/Cotton Wrap Fine Mercerized Cotton Silk A	12 stitches per inch
MEDIUMWEIGHT: Cotton, Cotton Blends, Percale, Gingham, Shantung, Pique, Seersucker, Satin, Knits, Vinyl, Suitings, Linen, Wool Crepe, Leather	14-RED	Polyester Core/Cotton Wrap 50 Mercerized Cotton Silk A	10 to 12 stitches per inch
MEDIUM HEAVYWEIGHT: Corduroy, Denim, Wool, Sailcloth, Wool Flannel, Gabardine, Velvets, Leather	14-RED or 16-PURPLE	Polyester Core/Cotton Wrap 50 Mercerized Cotton Mercerized Heavy-Duty Silk A	8 to 10 stitches per inch
HEAVYWEIGHT: Coatings, Upholstery, Cotton Duck, Heavy Twills, Canvas	18-GREEN	Polyester Core/Cotton Wrap Heavy-Duty Mercerized Cotton Polyester Synthetic Silk A	8 stitches per inch
Decorative top-stitching on all types of fabric	16-PURPLE 18-GREEN or Q-BLUE	Buttonhole Twist	6 stitches per inch
Synthetic Knits and Stretch: Polyester Double Knits, Nylon Tricot, Jersey, Stretch Terry, Spandex, Cire Tricot	Q-BLUE with "Q FOOT"	Polyester Core/Cotton Wrap 50 Mercerized Cotton	10 for Regular or 6 for Stretch Stitches

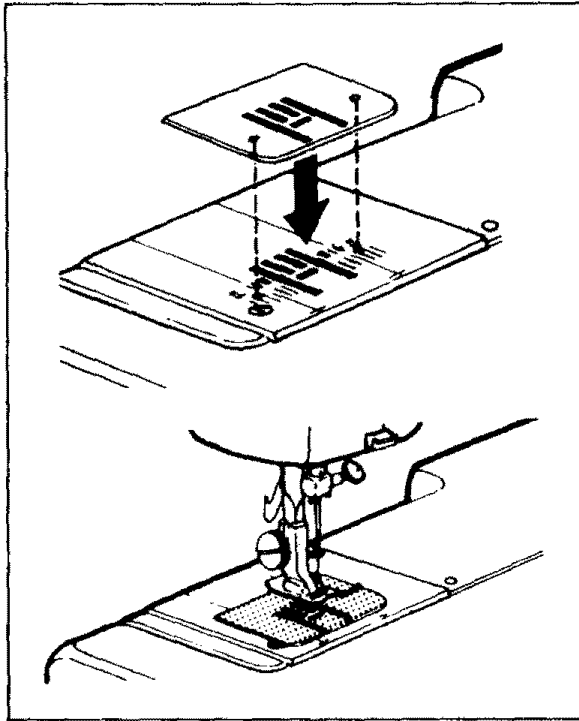

FEED COVER PLATE

There are a few times when you want to control the feeding of the fabric yourself. Raise needle to its highest position and raise presser foot. Place feed cover plate over needle plate aligning two pins of feed cover plate with holes of needle plate. You may then determine the movement of the fabric yourself.

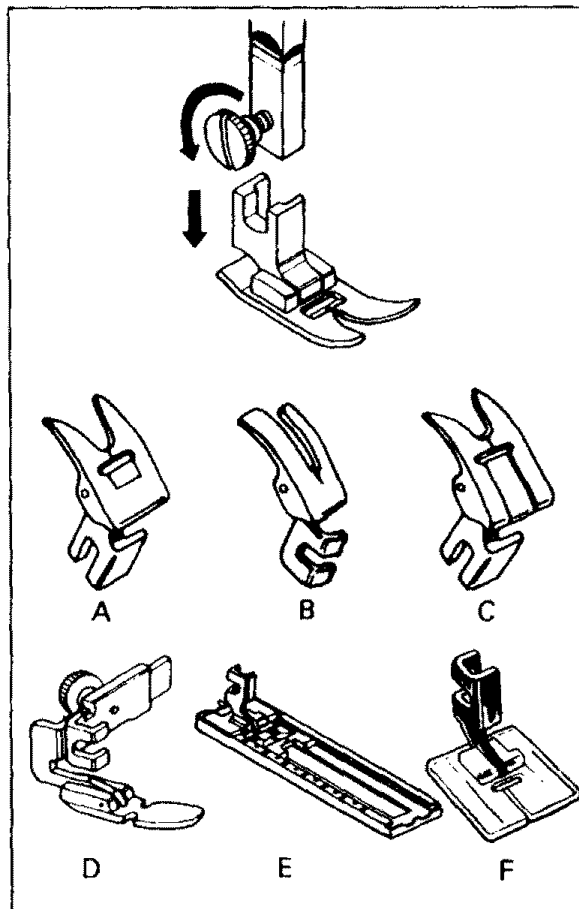

PRESSER FEET

To change the various presser feet, raise the presser bar to its highest position by lifting the presser foot lever (See page 15). Loosen the presser foot thumb screw, choose the proper foot, insert from the front. Lower the presser foot lever and tighten the screw using the large screw driver to make certain the foot is secure.

You have a variety of presser feet:

- A. Zigzag Foot
- B. Straight Stitch Foot
- C. Satin Stitch Foot
- D. Zipper Foot
- E. Buttonhole Guide Foot
- F. Buttonhole Foot

Applications are provided in appropriate sewing section.

CARING FOR THE MACHINE

CLEANING AND OILING

Fig. 1 Cleaning the feed dogs with a brush.

To insure the best possible operation of your machine, it is necessary to keep the essential parts clean at all times. Open shuttle access cover and remove needle plate with large screw driver. Then using a small brush, remove the lint that accumulates in the shuttle area and around the feed dogs.

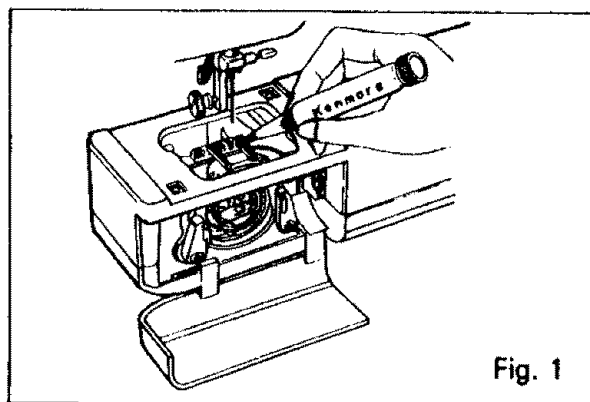

Fig. 1

Fig. 2 Parts of the Shuttle Assembly

To Clean the Shuttle Area:

1. This area must be kept free of dust, lint and occasional tangled thread. Raise the needle bar to its highest point and remove the bobbin case.
2. Push levers of shuttle race aside and lift shuttle race cover and shuttle out.
3. Clean the shuttle race with small brush.
4. Put a drop of Kenmore sewing machine oil only on the center pin of the shuttle and shuttle race (see arrows on two bottom illustrations).

To Replace Shuttle Assembly:

1. Position shuttle race as illustrated so that race is forming half moon on the left side of the machine.
2. Hold shuttle by center pin and position shuttle so as to form a half moon on the right side. Pointed hook will be on the bottom.
3. Place shuttle race cover into place over shuttle assembly.
4. Snap the levers into position.

Note: Oil and lint brush No. 6889 is available at most Sears retail stores and catalog.

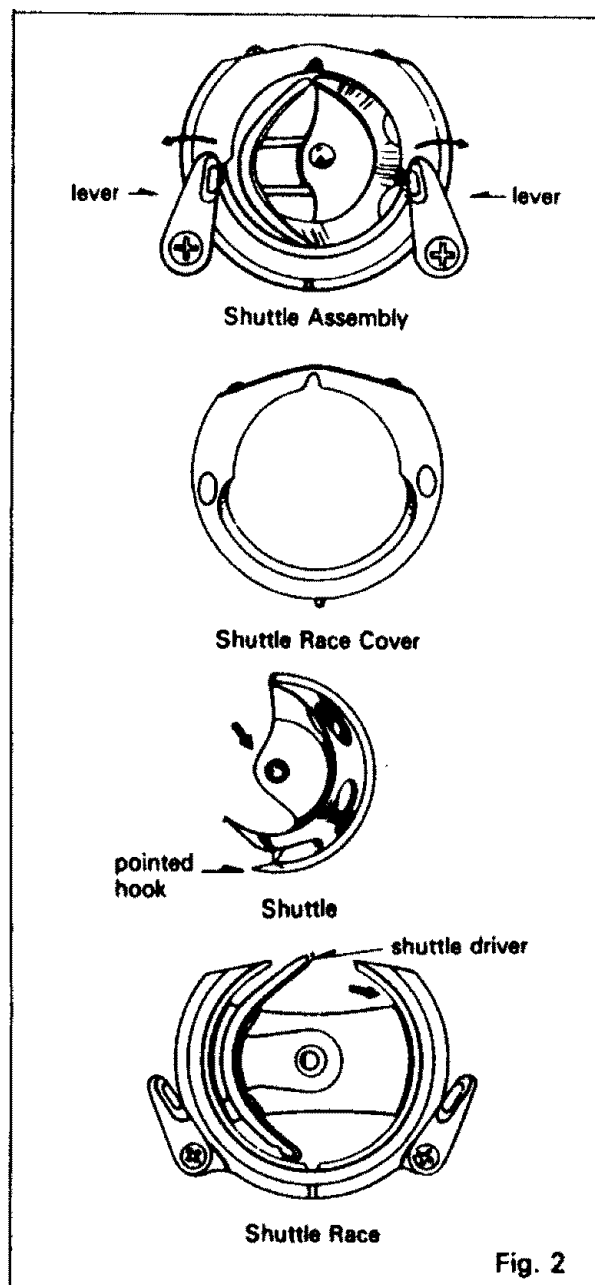
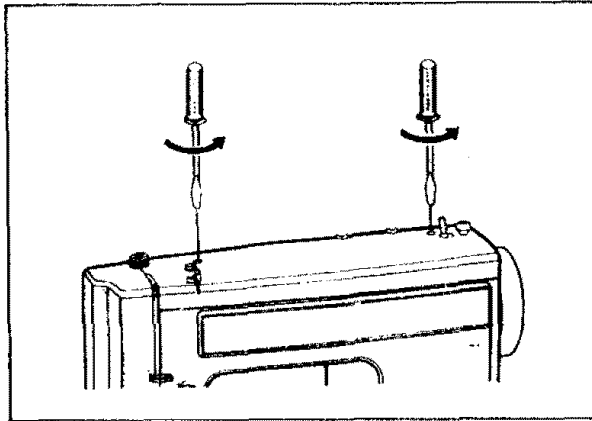
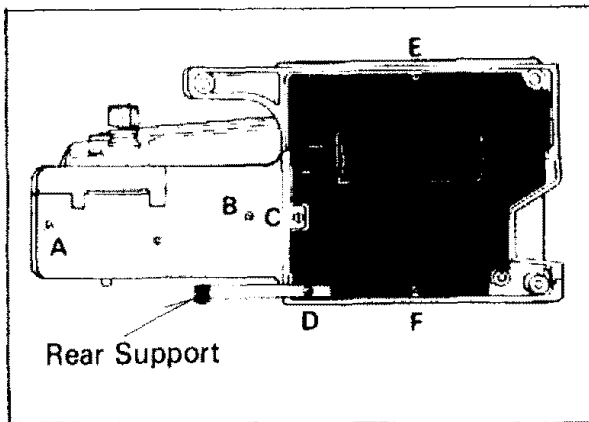
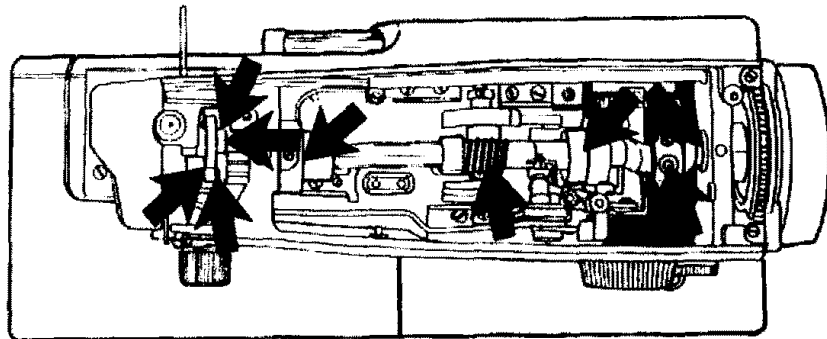

Fig. 2



OILING UNDER TOP COVER PLATE

Remove arm cover plate to oil points indicated by arrows in top of machine head. Use one to two drops of Kenmore sewing machine oil at each part. To remove cover plate, loosen up two top screws and lift the cover plate.



OILING UNDERSIDE

Tilt machine head back and remove bottom covers and rear support to oil points indicated by arrows on underside of machine. To remove bottom covers and rear support, remove screws (A), (B), (C), (D), (E) and (F).

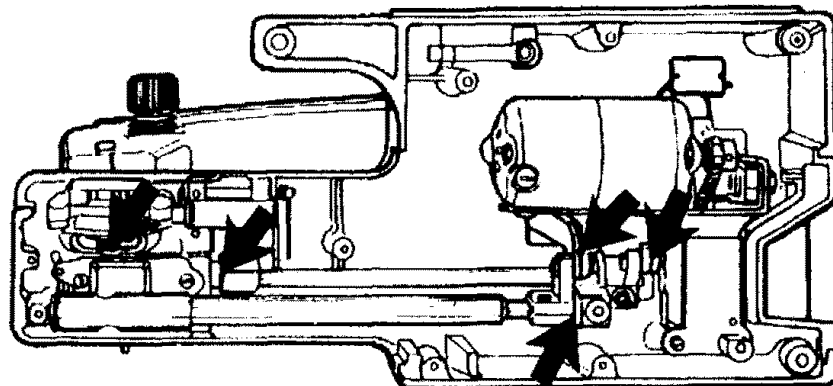

OILING IN FACE COVER PLATE

Swing face cover plate open and oil points indicated by arrows in illustration.

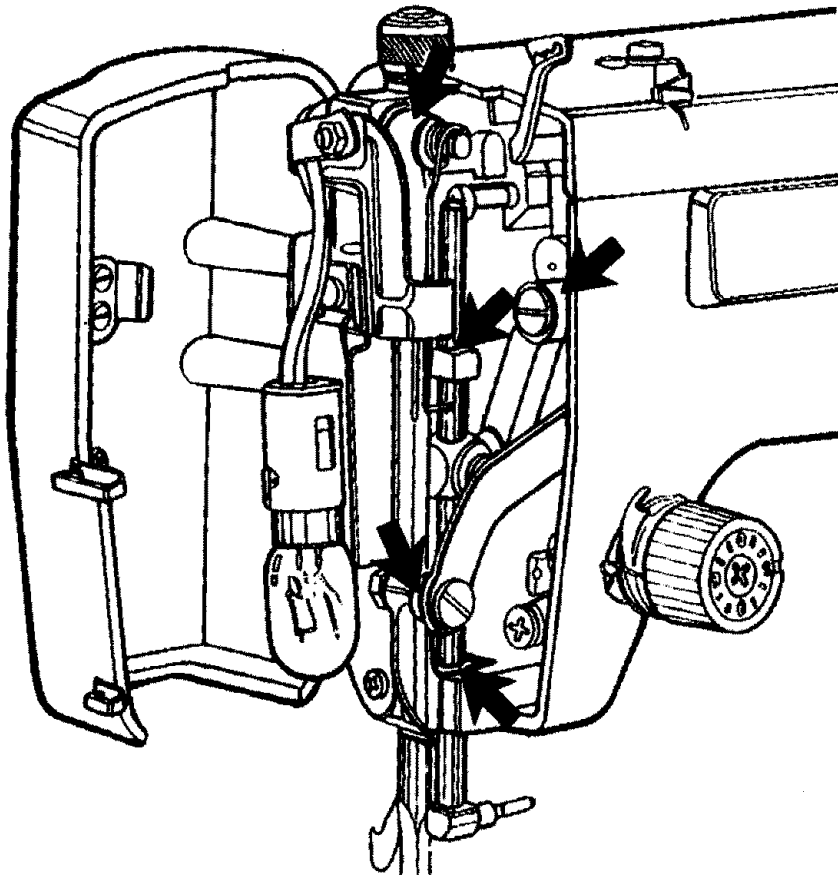

CHANGING LIGHT BULB

The sewing light is located inside the face cover plate as shown. To replace the bulb, push switch to off, unplug machine and swing the face cover plate open. Push up on the bulb slightly and turn bulb to the left. Withdraw bulb from socket. Push in new bulb and turn to the right.

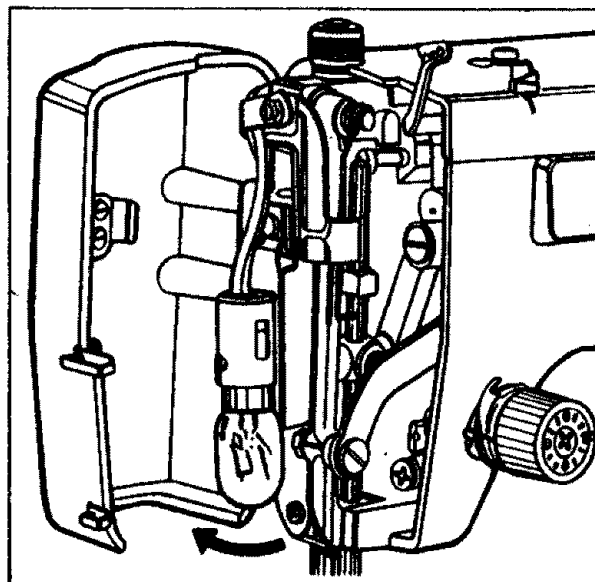

CHECKING PERFORMANCE PROBLEMS

SUSPECTED PROBLEM	PROBABLE CAUSE
IRREGULAR STITCHES	<p>Incorrect size needle. Improper threading. Loose upper thread tension. Pulling fabric. Light pressure on presser foot. Loose presser foot. Unevenly wound bobbin. Nicks or burrs at needleplate opening.</p>
BREAKING NEEDLE	<p>Pulling fabric. Incorrect size needle. Incorrect setting of needle. Loose presser foot.</p>
BUNCHING OF THREAD	<p>Upper and lower threads not drawn back under presser foot before starting seam.</p>
PUCKERING	<p>Incorrect thread tension(s). Light pressure on presser foot. Using two different sizes or kinds of thread. Bent or blunt needle. Loose presser foot. Fabric too sheer or too soft.</p>
SKIPPING STITCHES	<p>Incorrect size needle. Certain knits and synthetics. Bent or blunt needle. Incorrect setting of needle. Tight upper thread tension. Light pressure on presser foot.</p>
BREAKING UPPER THREAD	<p>Starting to stitch too fast. Improper threading. Tight upper thread tension. Incorrect size needle. Sharp eye in needle. Nicks or burrs at needleplate opening.</p>
BREAKING BOBBIN THREAD	<p>Improper bobbin case threading. Lint in bobbin case or shuttle.</p>
FABRIC NOT MOVING	<p>Feed cover plate attached or feed dog down. Light pressure on presser foot. Thread knotted under fabric.</p>
MACHINE JAMMING, KNOCKING NOISE	<p>Thread caught in shuttle. Damaged needle. Bent needle plate.</p>
MACHINE DOES NOT SEW	<p>Power cord not connected. Power/light switch off.</p>

POSSIBLY EASY CORRECTION

Choose correct size needle for thread and fabric.
Rethread machine; check tension spring threading.
Tighten upper thread tension.
Do not pull fabric; guide it gently.
Increase pressure on presser foot.
Reset presser foot.
Rewind bobbin.
Replace needleplate, or polish off burrs completely.

Do not pull fabric; guide it gently.
Choose correct size needle for thread and fabric.
Reset needle.
Reset presser foot.

When starting a seam be sure to draw both threads under and back of presser foot about 4" and hold until a few stitches are formed.

Reset thread tension(s).
Increase pressure on presser foot.
Upper thread and bobbin thread should be same size and kind.
Insert new needle.
Reset presser foot.
Use underlay of tissue paper.

Choose correct size needle for thread and fabric.
Use "Q NEEDLE"™ and "Q FOOT"™.
Insert new needle.
Reset needle.
Loosen upper thread tension.
Increase pressure on presser foot.

Start to stitch at a medium speed.
Rethread machine.
Loosen upper thread tension.
Choose correct size needle for thread and fabric.
Insert new needle.
Replace needleplate, or polish off burrs completely.

Check bobbin case threading.
Clean bobbin case and shuttle.

Remove feed cover plate or raise feed dog.
Increase pressure on presser foot.
Place both threads back under presser foot before beginning to stitch.

Disassemble and clean shuttle.
Replace needle.
Replace needle plate.

Check plug.
Push to on position.

2. STARTING TO SEW

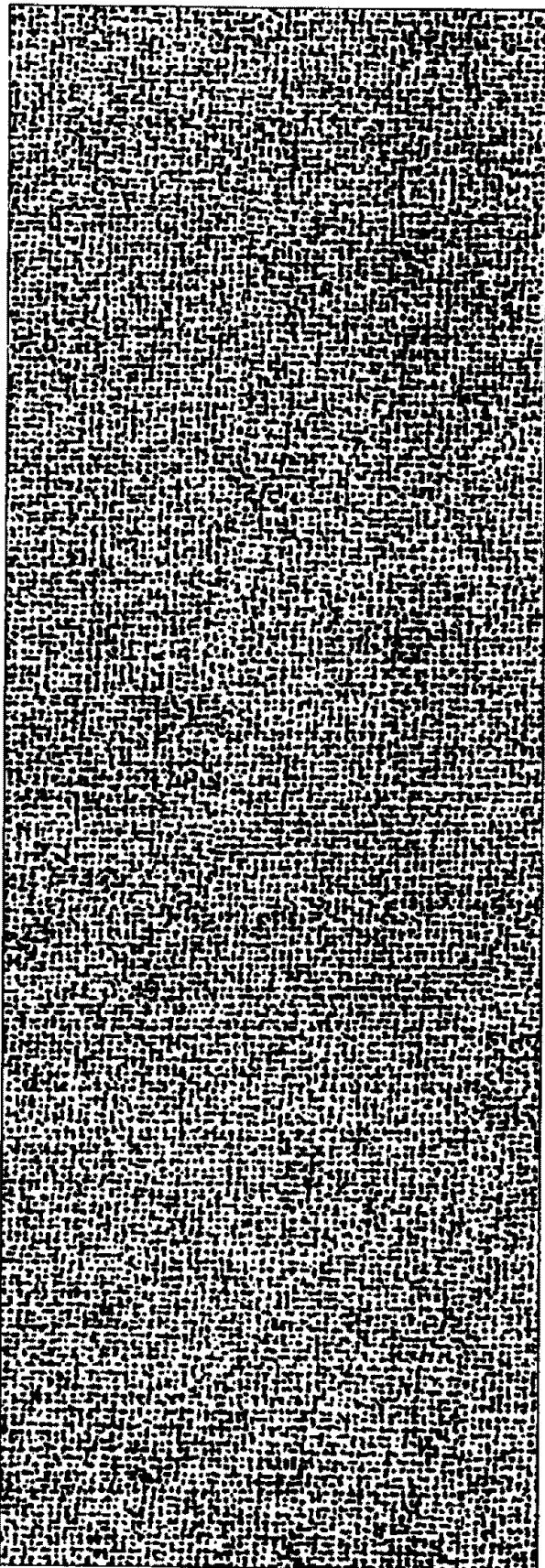

Now that you are familiar with the controls on your machine and with the accessories provided for the machine, you are ready to start to sew with your sewing machine. Below are some good habits to follow each time you sit down to sew:

1. Check the needle-it should be straight, properly set and sharp on the point. It should be the correct size for the fabric and thread being used. Do not be afraid to change your needle frequently. Many of the new fabrics made of synthetic blends tend to dull the needles more easily than fabrics made of natural fibers.
2. Before placing the material on the machine, see that the ends of the threads have been drawn about 3 - 4 inches to the rear of the machine. Hold on to threads during the sewing of the first 3 or 4 stitches of the seam.
3. Test the machine stitch on a scrap of fabric you plan to use. The fabric should be double thickness. Adjust the machine for the length of stitch and tension suitable to your fabric.
4. Fabric should be placed under the presser foot with the bulk of the material to the left of the needle and the right edge of the material placed on the 5/8" seam marking on the needle plate when making a simple seam.
5. Run the machine at a slow even speed. The more pressure you put on the foot control, the faster the machine will sew.
6. Fasten each seam by back tacking at the beginning and end of the seam.
7. Always finish sewing each seam with the needle at its highest point.
8. Guide the fabric gently with your hand in front of the needle. Never pull or hold the fabric in such a way that the normal feeding is altered.
9. When turning the hand wheel manually, always turn it toward you.

STRAIGHT STITCHING

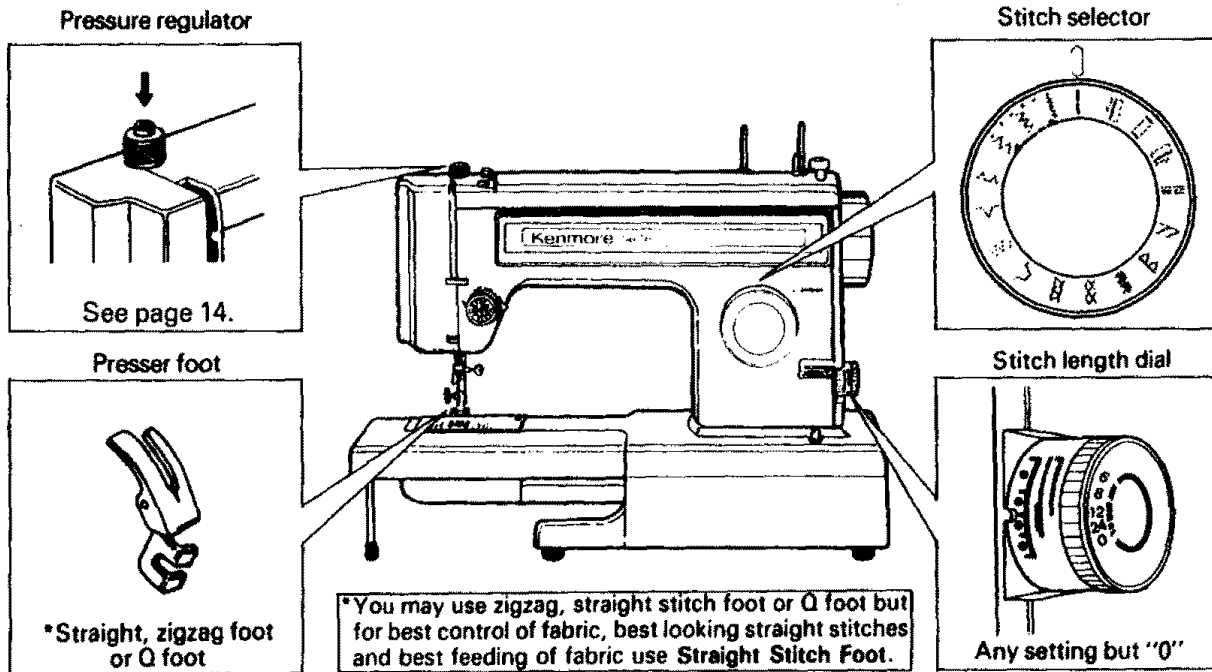

FASTENING A SEAM

Be sure both threads are drawn back under the presser foot. Lower needle into fabric about 1/2 inch from beginning of seam. Depress the reverse stitch lever and stitch in reverse until needle reaches beginning of seam. Release control and complete seam. When you reach the end, depress the reverse stitch lever and sew back (backtack) over 1/2 inch of completed seam.

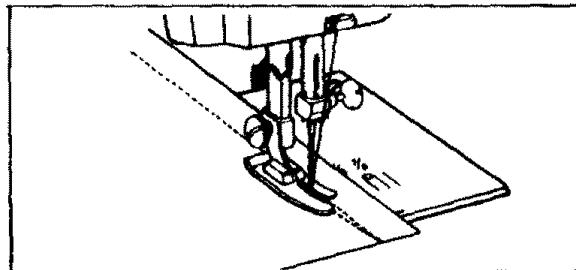

TURNING A SQUARE CORNER

To turn a square corner 5/8" from the fabric edge, stop stitching with the needle piercing the fabric, when reaching the cornering guide as shown. Raise the presser foot, turn fabric. New stitching line will align with 5/8" seam guide on side of needle plate. Lower the presser foot and begin stitching in new direction.

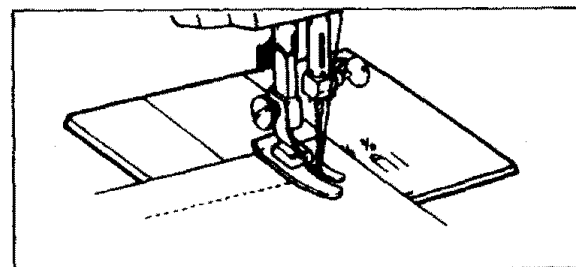
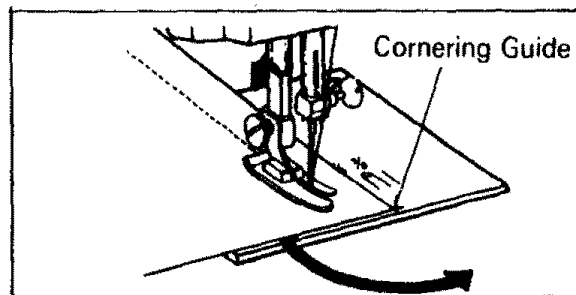

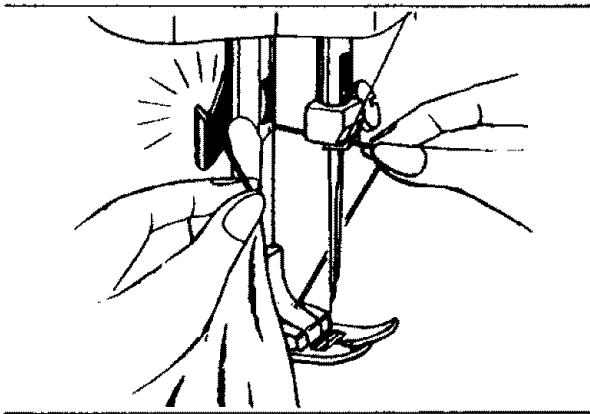

REMOVING FABRIC

First turn the handwheel toward you until the needle is at its highest position, then raise the presser foot, draw materials to the rear and cut off excess thread with the thread cutter located on the presser bar as shown.

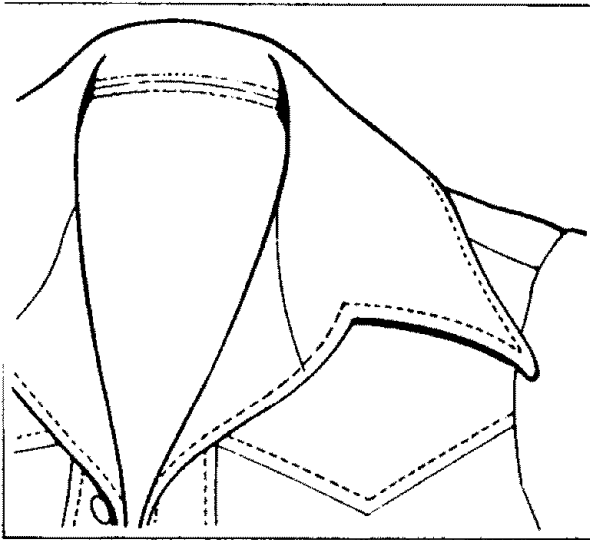

TOP-STITCHING

This is a seam you may want to show off! It's on the front side of the garment, possibly at the top of a "kick pleat" or on a lapel, both functional and decorative. Usually, it's a simple, forward stitch — with an extra-long stitch length, or with special thread, matching or contrasting.

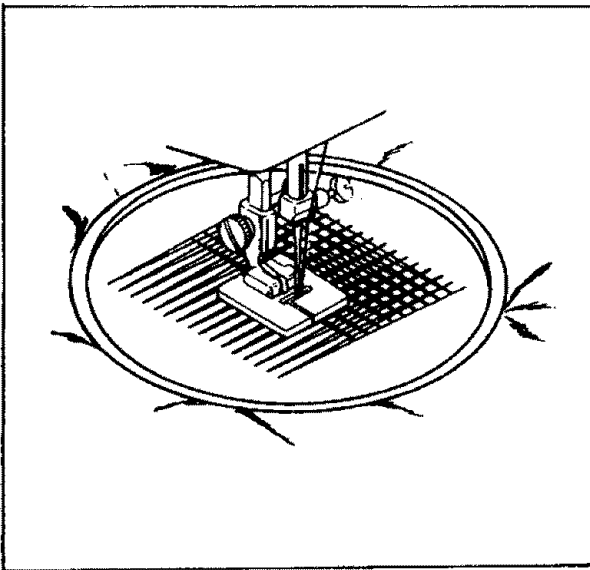

DARNING

SETTINGS

Stitch Selector - 1

Stitch Length - 8 to 10

Zigzag foot or square automatic buttonhole foot

Release Presser Foot Pressure.

Stretch fabric between embroidery hoops with hole centered. Lower presser bar and sew at a slow speed moving fabric back and forth with a steady rhythm to cover darning area. When it is covered, turn fabric 1/4 a turn and sew layer of stitching across first layer.

If fabric is thin or badly damaged in hole area, you may want to put a separate piece under the hole for reinforcement.

TEMPORARY SEWING BY MACHINE

No longer do you need to baste by hand!

Basting by machine is easy—simply use straight stitching with longest available length setting.

PIN BASTING

You can sew over pins easily (if done correctly) because your presser feet are hinged. Pins must be inserted at right angles to seam line. Tip of pin should just touch seam line. Sew over tip of pins. Pins must not come in contact with feed dogs: **Never** pin on the under-side of the fabric. Sew slowly. If in doubt about sewing over pins, remove each pin as you approach it.

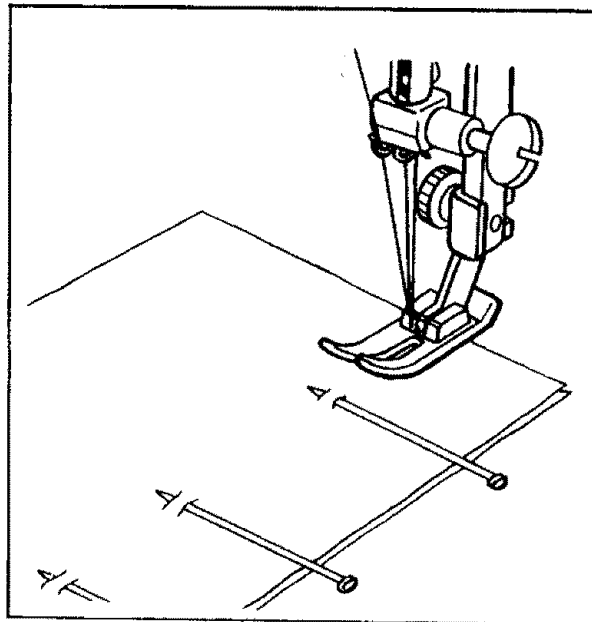

STAY-STITCHING

“Stay-stitching” is a form of temporary seaming that prevents stretching of curved edges of garments. Usually this is on a single layer of fabric, so reduce top thread tension slightly to prevent puckering. Baste about ¼" away from intended seamline.

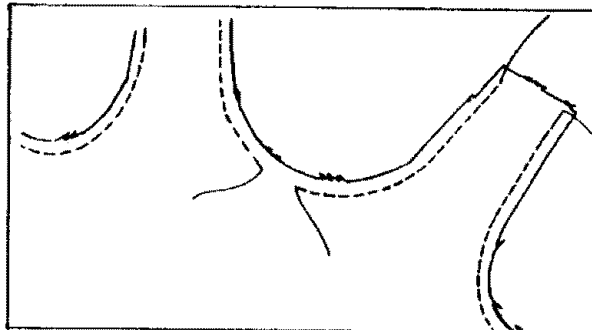

ZIPPER APPLICATION - CORDING

REGULAR ZIPPER

The foot is adjustable for use on the right or left side of needle when sewing regular type of zipper. Adjust the foot so the needle clears the side notch on the foot. Carefully follow directions given on the zipper package.

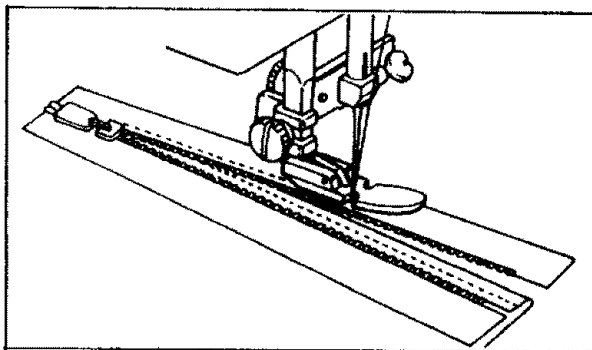

CORDING

To make cording for slipcovers, etc., cover a cord with a strip of true bias. Adjust the foot to the left of the needle.

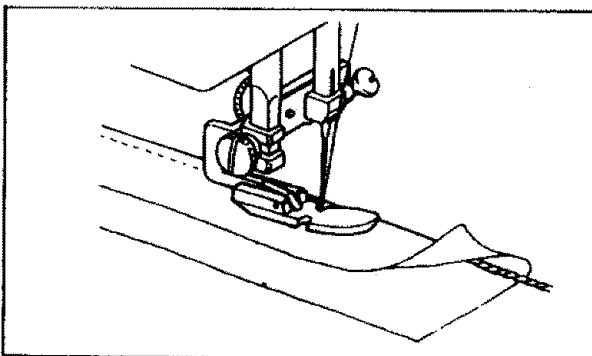

ZIGZAG STITCHING

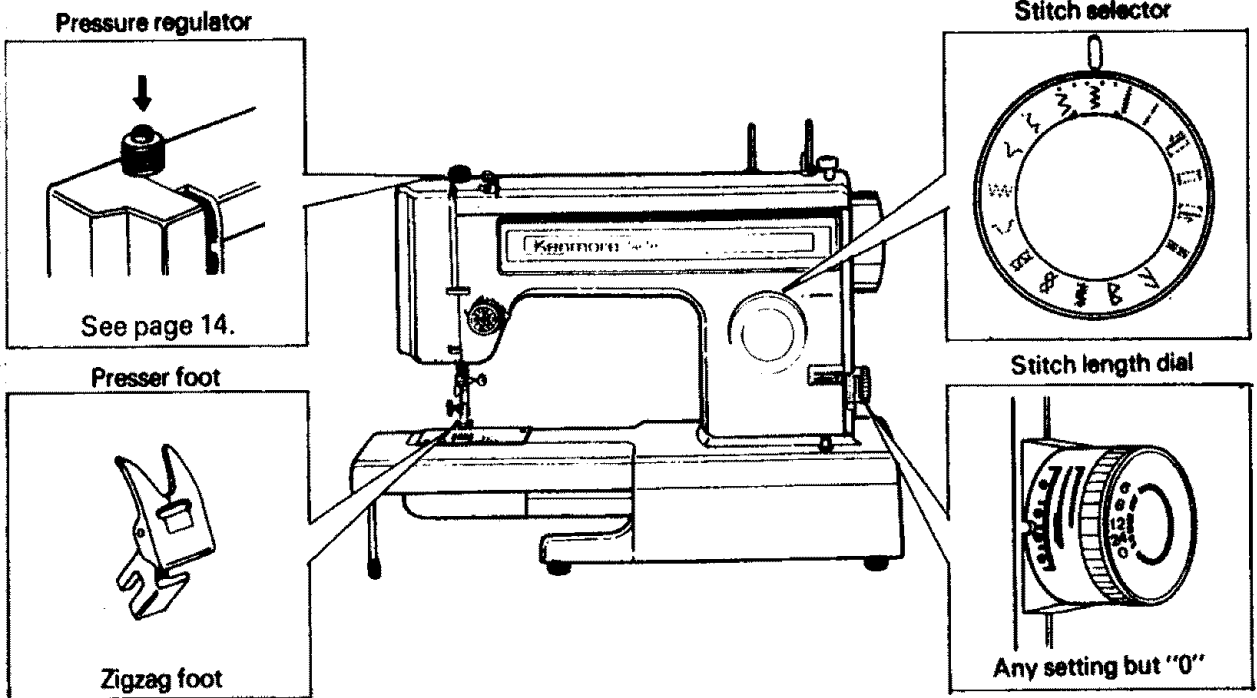

TOP VIEW

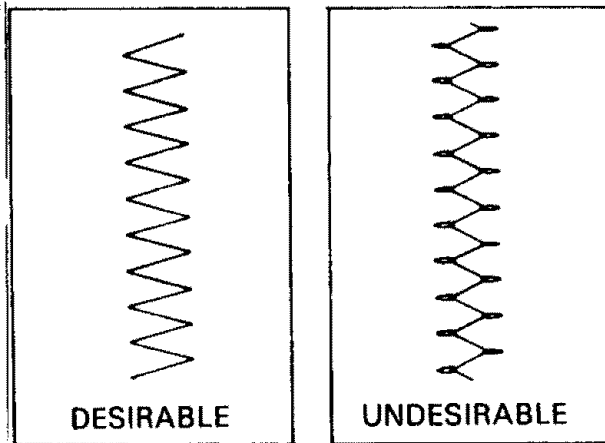

CHECKING THREAD TENSION OF ZIGZAG STITCHES

The easiest way to check tension is to sew a medium zig zag stitch on the fabric you will be using. Use the appropriate type of thread and needle as recommended on page 17.

Sew a line of zig zag stitches. The bobbin thread should not show on the top of the fabric.

Adjust the top tension if necessary to achieve the stitch indicated at left side of illustration.

OVERCASTING

This is one of the more frequently used zigzag stitches on garment construction. You may want to overcast along the raw edge of each seam allowance or fold the raw edge toward the garment and stitch.

Stitch so the needle pierces the fabric just short of the outside edge. Raw or worn edges of older garments can be overcast to prevent further raveling.

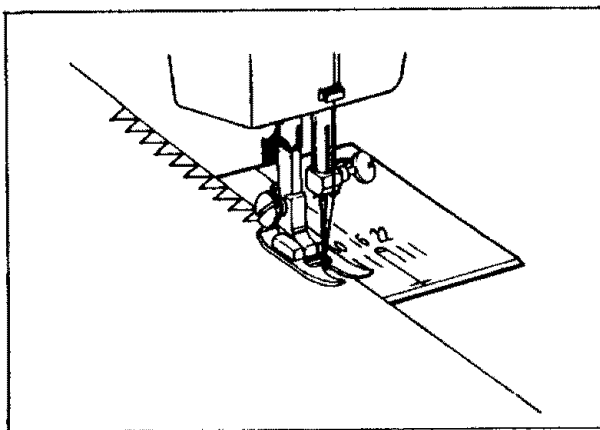

SATIN STITCHING

SETTINGS

Stitch Selector - Zigzag Stitch
Stitch Length Dial - Between 0 and 24
Satin Stitch Foot

Closely spaced zigzag stitches are called satin stitches. This is an attractive stitch used for appliqueing, bar tacking.

Whenever you are using this stitch, it is well to remember to loosen the tension of the top thread slightly. The wider the stitch you make, the looser the tension should be.

If you are stitching on a very soft fabric, use a backing of tissue paper or interfacing for a well formed stitch. Puckering of the material will be eliminated and the bobbin thread will not be visible on the right side of the fabric.

As with all special stitches, it is best to make a sample design on your fabric before starting the design on the garment.

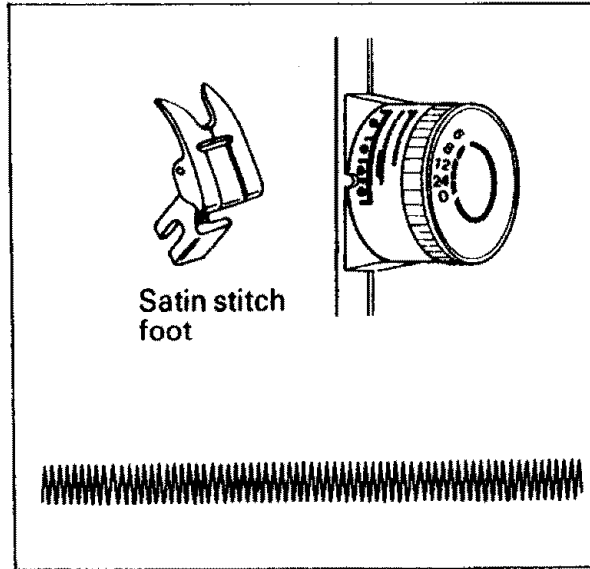

BAR TACKING

SETTINGS

Stitch Selector - Zigzag Stitch
Stitch Length Dial - Between 0 and 24
Satin Stitch Foot

This stitch is similar to a very short satin stitch and is used to reinforce points of strain such as corners of pockets and straps on lingerie.

Sew 4 to 6 zigzag stitches.

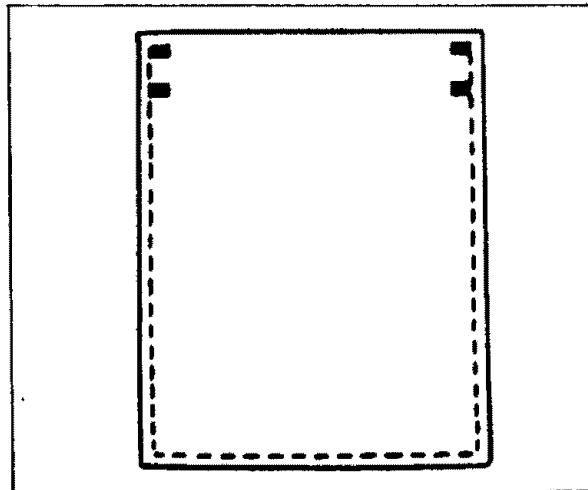

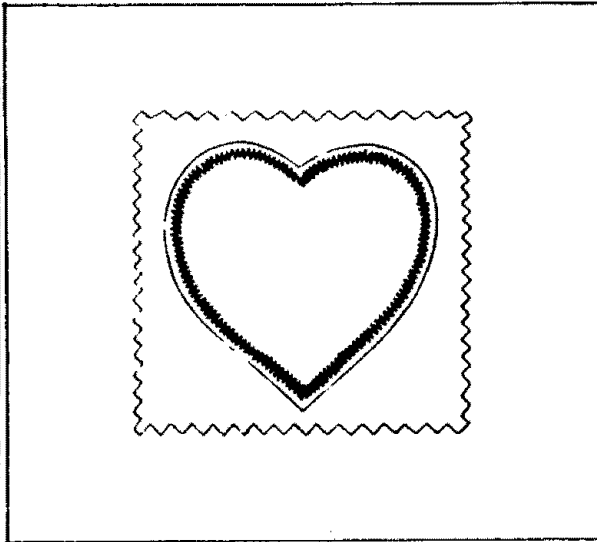

APPLIQUEING

SETTINGS

Stitch Selector - Zigzag Stitch
 Stitch Length Dial - Between 0 and 24
 Satin Stitch Foot

Select an applique design to be applied to your garment and baste it in place. Satin stitch around the raw edge of the applique completely covering the edge. You may want to do this with a contrasting color of thread.

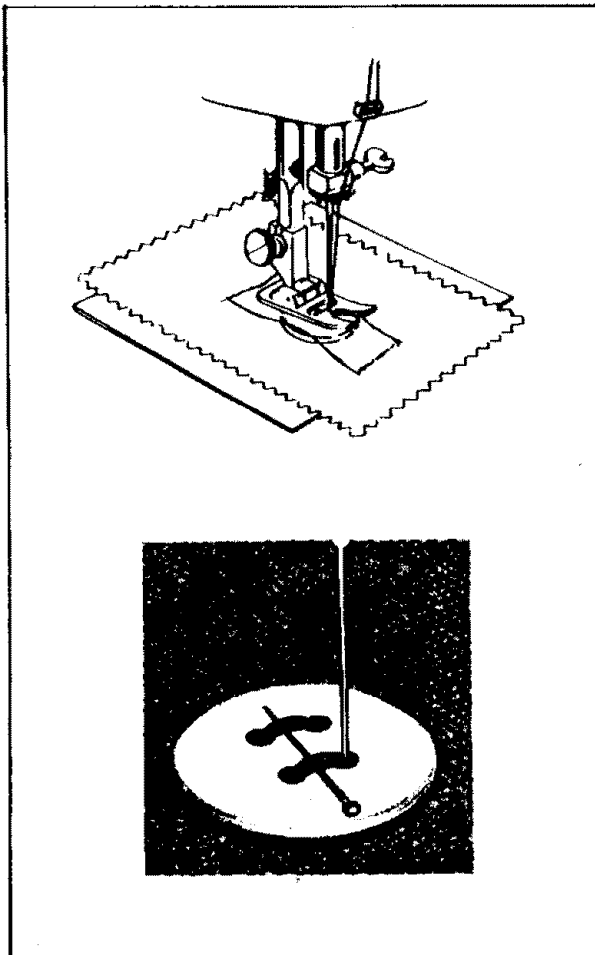

BUTTON SEWING

SETTINGS

Stitch Selector - Zigzag Stitch
 Use Feed Cover Plate or Feed Dog Down.

1. Fix the button on fabric at desired position with clear tape.
2. Align two holes of button with slot of presser foot and lower foot to hold the button securely.
3. Turn hand wheel manually until needle point is just above button.
4. Set stitch selector at desired zigzag stitch position so needle will enter one hole of the button.
5. Turn hand wheel again by hand so needle enters second hole. Reset stitch selector if necessary. Stitch a number of times.
6. Finish sewing with an extra two inches of thread remaining. Draw these threads to reverse side of garment and tie.

When sewing a flat button, place needle or pin between holes of button as shown to provide flexibility for buttoning.

BLIND HEMMING

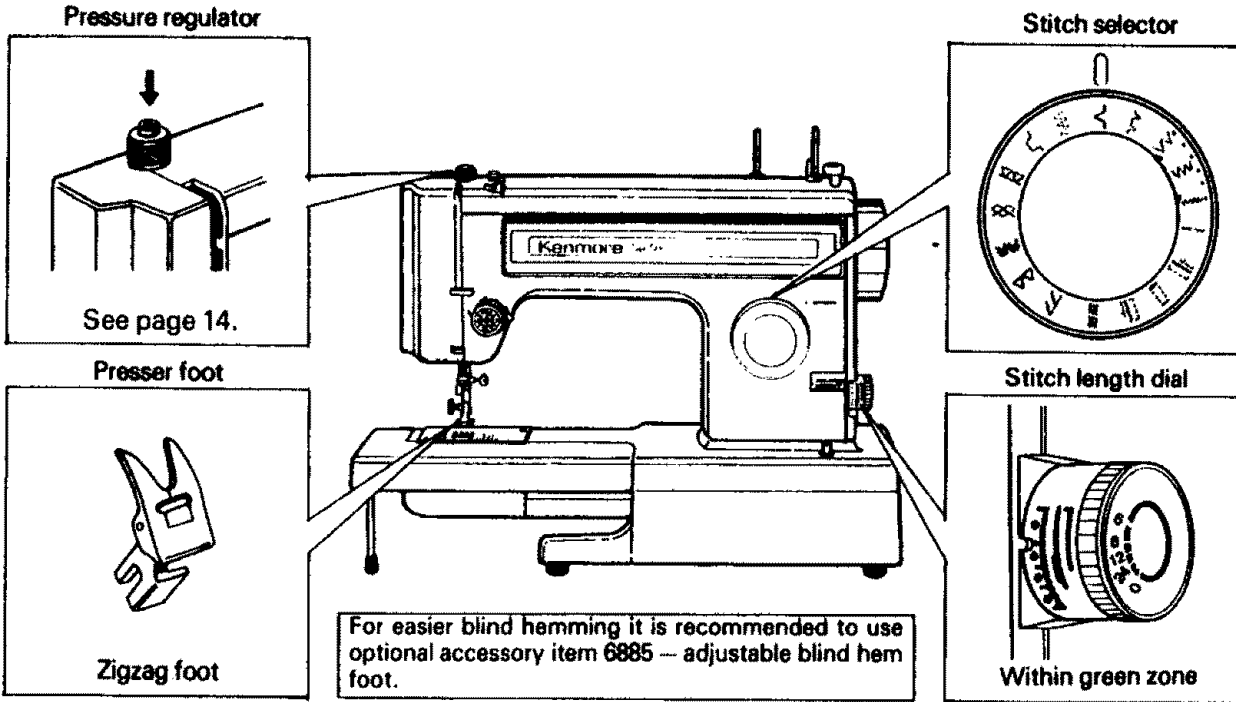

PROCEDURE

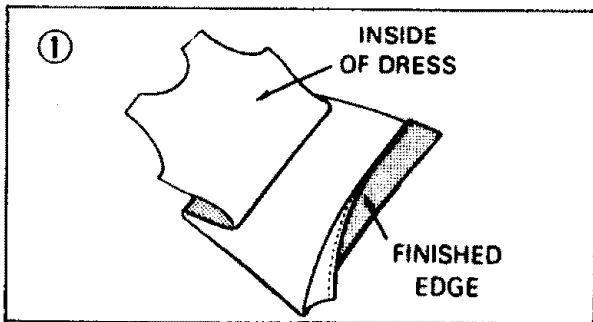

Finish edge of hem anyway you desire. Turn up hem appropriate width.

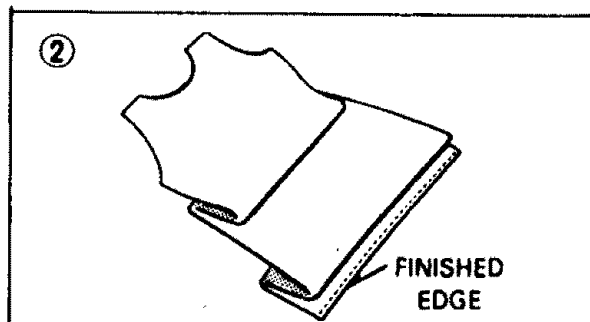

Fold garment away from hem leaving 1/8" of hem edge extending.

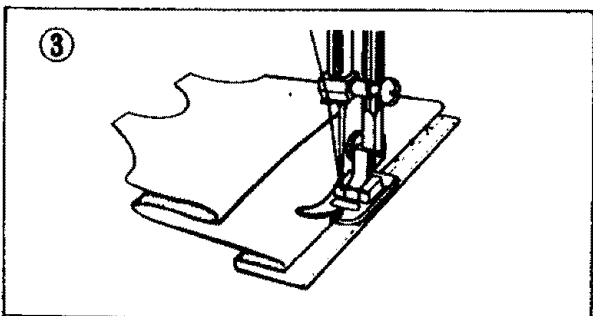

Place garment under presser foot in such a manner that straight stitches will be sewn on extended edge. The zigzag stitch should just catch the fold of the garment.

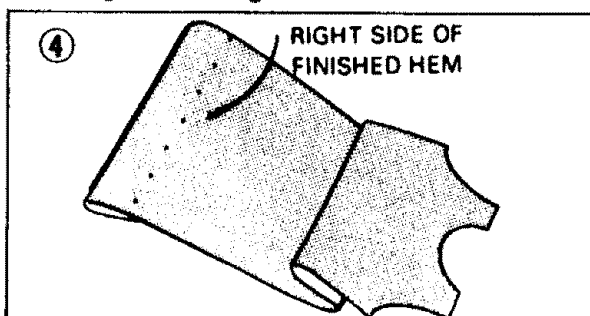

Press both sides of the finished hem. The right side of the garment will show only the blind stitches.

MENDING AND OVERCAST STITCHING (THREE-STEP ZIGZAG)

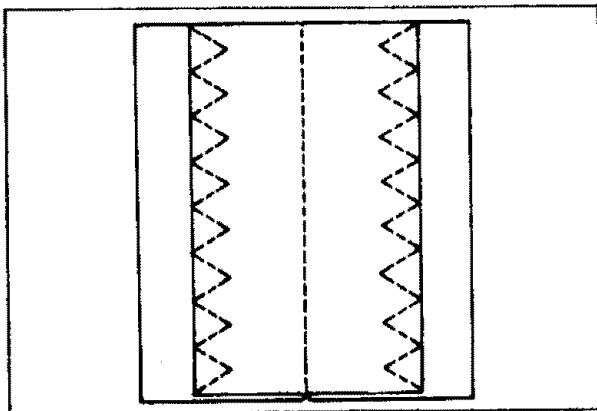
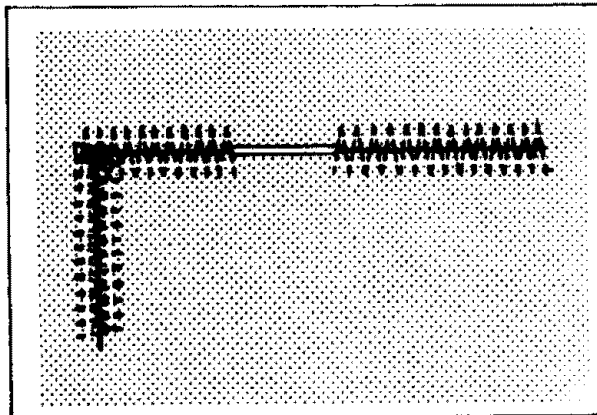
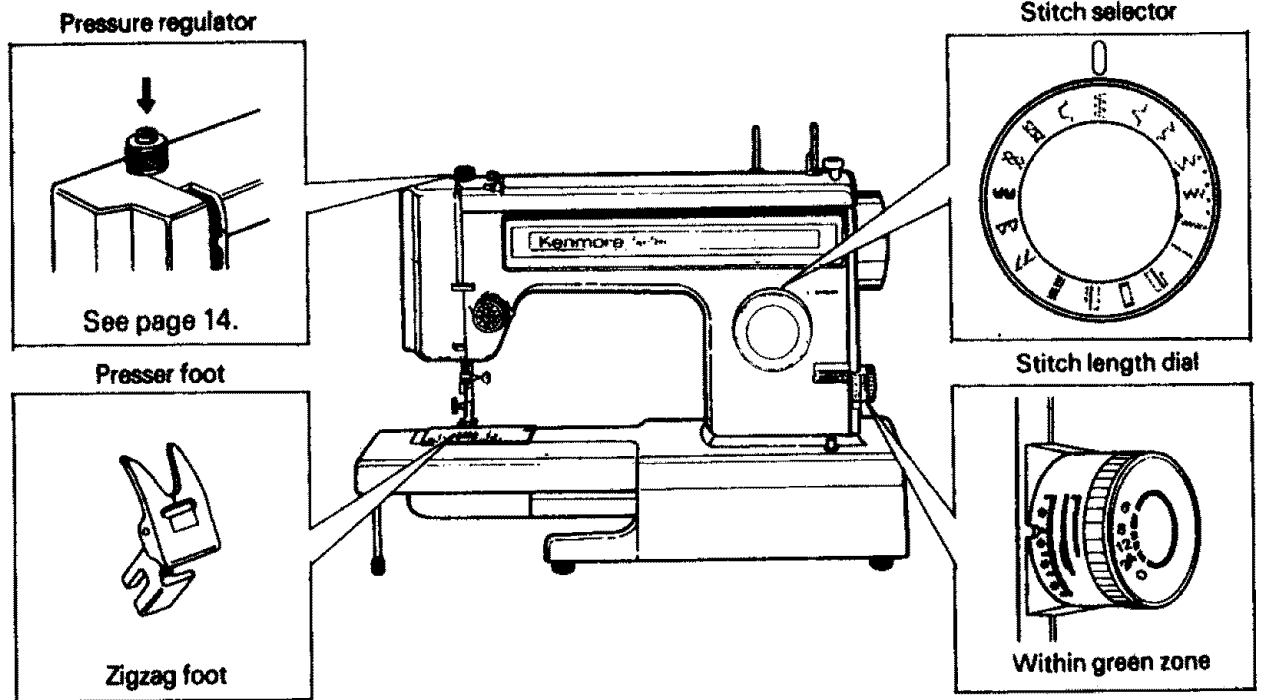

MENDING

To repair a straight or three-cornered tear, position the tear under the needle in such a way that the stitching catches both sides of the tear. When mending a three-cornered tear, stitch from each end to the center. It is well to use a piece of fabric under the tear for reinforcement.

OVERCASTING WITH MENDING STITCH

Three-step zig-zag is a strong stitch because, as its name implies, it takes three short stitches where normal zig-zag takes one. For this reason it is highly recommended for overcasting, i. e. finishing a raw edge, on all types of fabric.

SHELL STITCHING

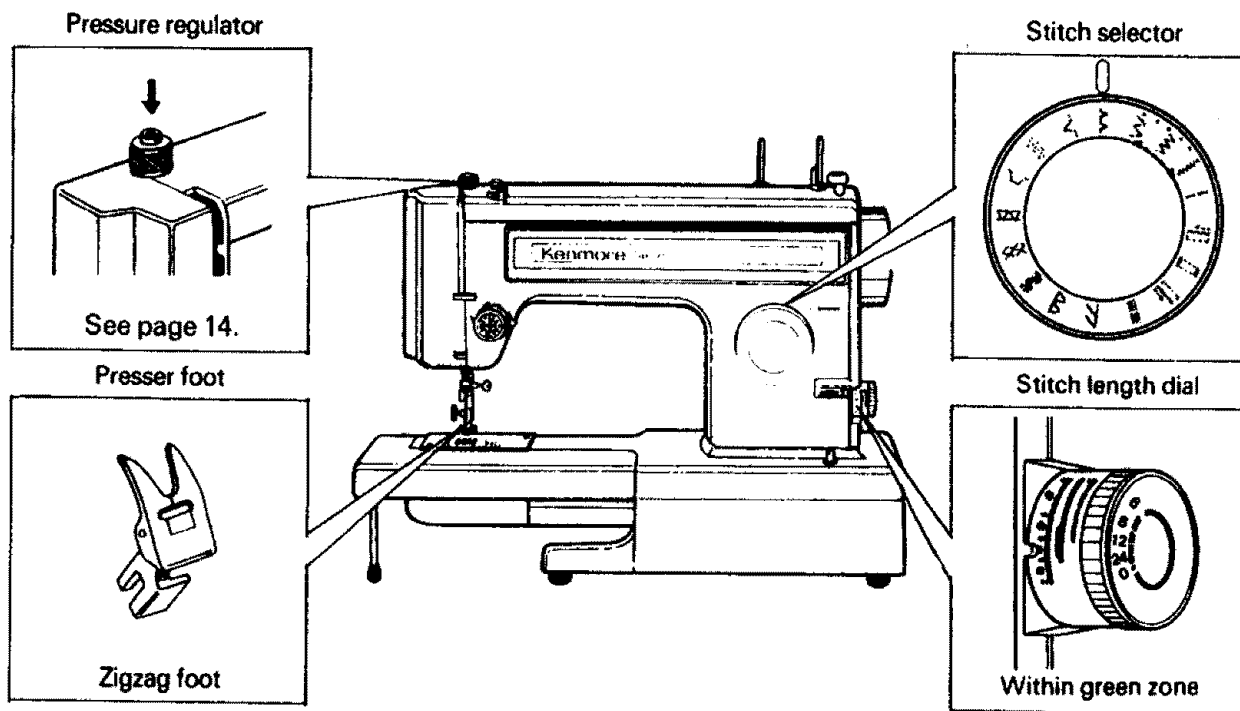

PROCEDURE

This shell-stitched edge is a popular finish for lingerie and nightgowns. To achieve this multiple scalloped effect, allow needle to just clear the right edge of the fabric when it zigzags.

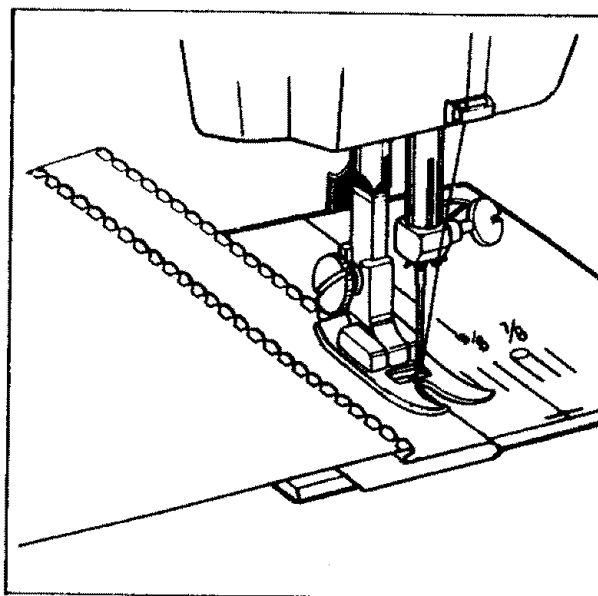

BOX STITCH

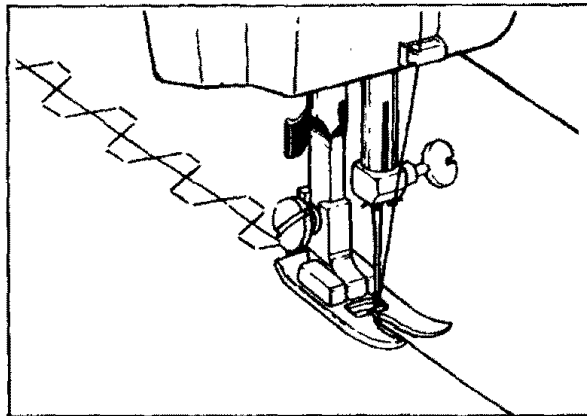
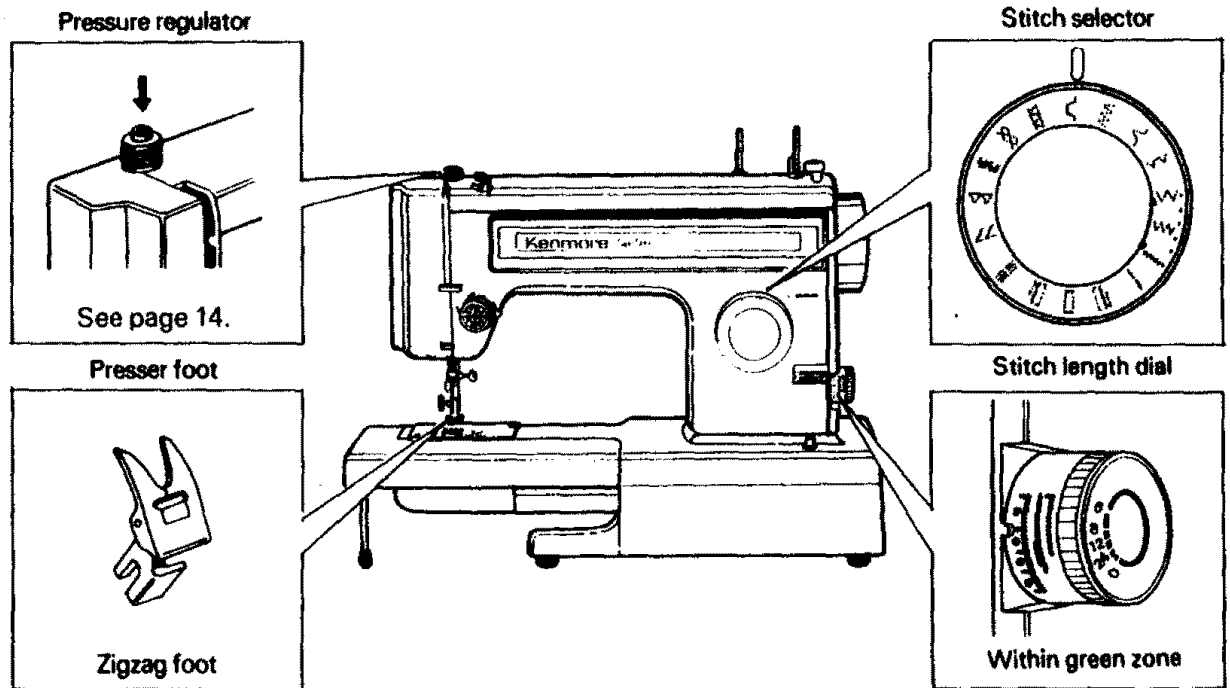

OVERLAPPED SEAM

Box stitch is ideal for producing flat overlapped seams on almost any type of fabric and a bolder effect will result from sewing with a contrasting thread.

Overlap the raw edges of two pieces of fabric 2" and pin or tack. Place the fabric right side up with the middle of the overlap under the center of the presser foot, so that the stitch sews just over the top and bottom raw edges.

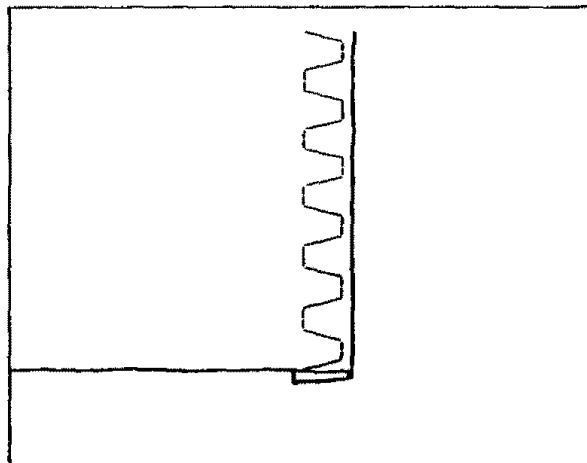

DECORATIVE EDGING

Turn the raw edge under 2" and press. Place the fabric right side up with the middle of the turnover under the center of the presser foot, so that the stitch sews on to the fold and just over the raw edge underneath.

STRETCH STITCHES

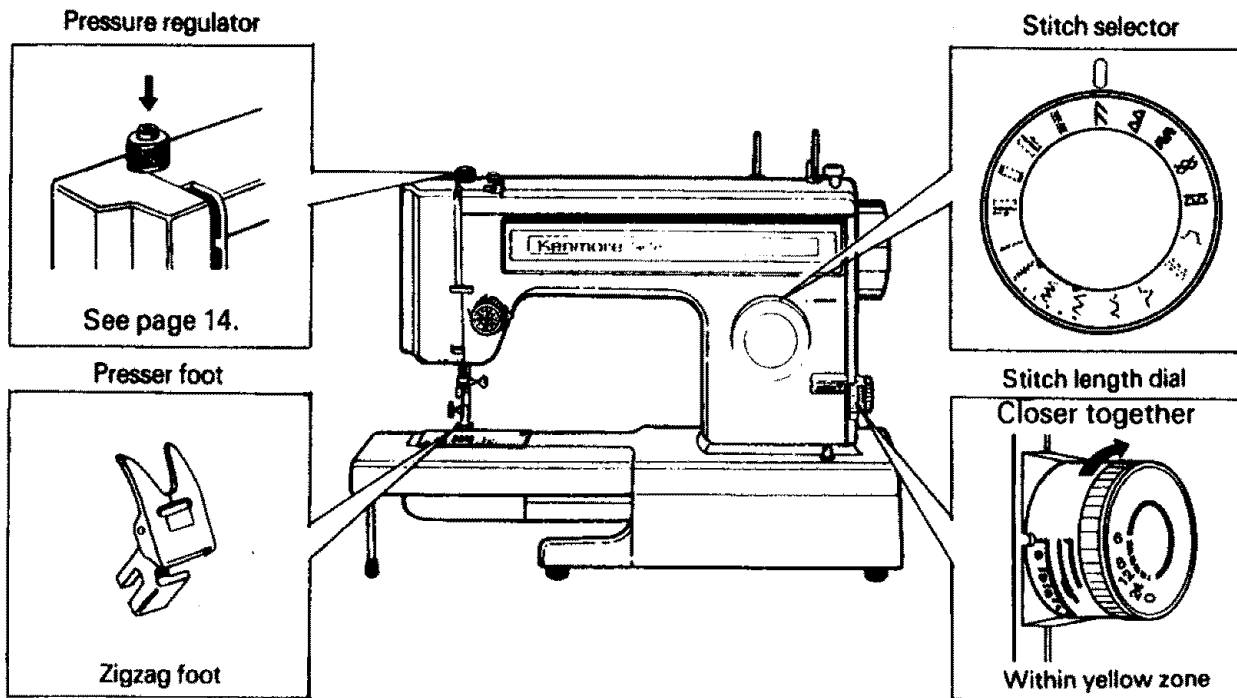

The stitches shown at left are all for use with stretch and knit fabrics. These are special stitches built in to the machine for your quick selection.

1. Straight Stretch
2. Serging or Pine Leaf Stretch
3. Overcast Stretch
4. Rick-Rack Stretch
5. Smocking Stretch
6. Elastic Stretch

ADJUSTING STITCH LENGTH

Depending upon your preference in stitch patterns, you may make stretch stitches closer together without changing the balance of stitches by turning stitch length dial away from you within yellow zone.

RECOMMENDATION

It is recommended to use "Q NEEDLE" and "Q FOOT" for sewing on knit and synthetic fabric.

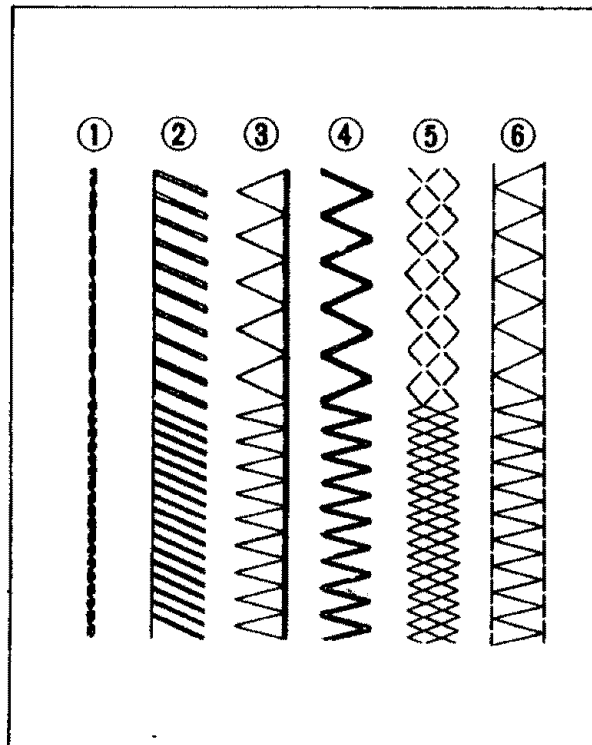

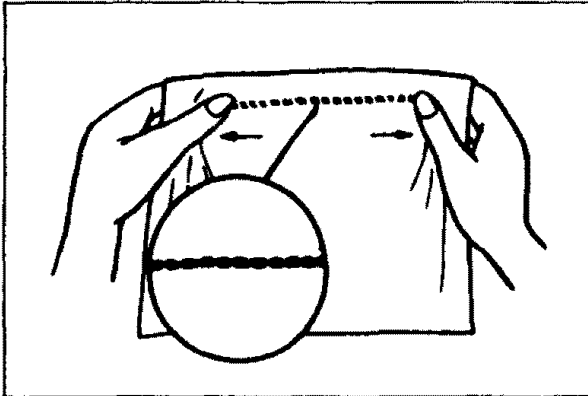
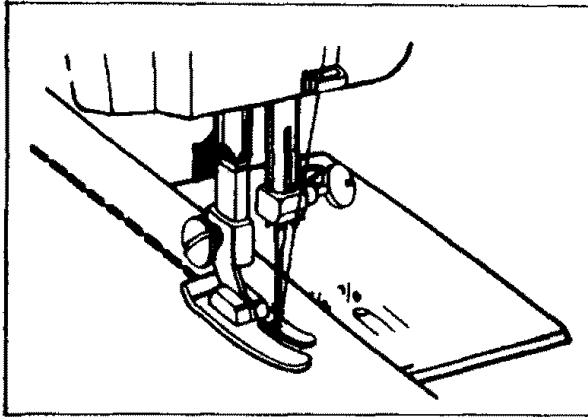

STRAIGHT STRETCH STITCH

SETTINGS

Stitch Selector - 

Stitch Length - Yellow Zone

You may use either a zig zag or straight stitch foot BUT-- for best control of fabric, best looking straight stitches and best feeding of fabric use **Straight Stitch Foot**.

Use this stretch stitch with knit or synthetic fabric. Sew as you do with regular straight stitch.

This is also a good stitch to use on curved seams regardless of the type of fabric. Any seam that will receive a great deal of strain when worn should be sewn with the stretch stitch. Use in children's shorts and slacks as well as adult sports clothes.

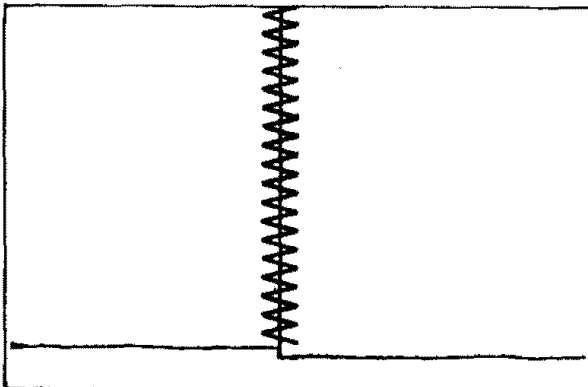
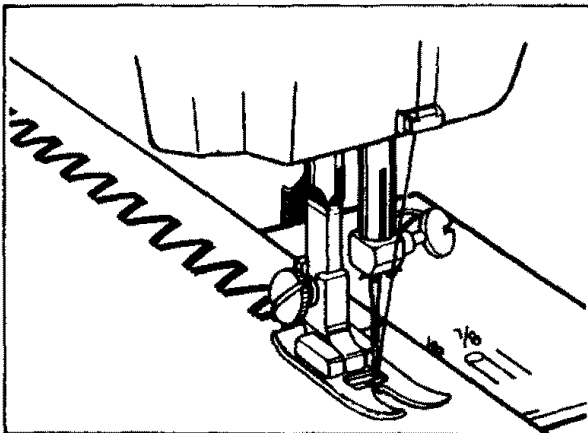

RICK-RACK STRETCH STITCH

Stitch Selector - 

Stitch Length - Yellow Zone

Sew on stretch fabrics in any area that you might use a zig zag stitch. This stitch can be used as a decorative top stitch as well.

It is useful also on lapped or abutted seams where you lap one edge of a seam over another with seamlines meeting in the center.

SMOCKING STRETCH STITCH

Stitch Selector - 
Stitch Length - Yellow Zone

1. Make a straight line of gathers across the fabric that you wish to smock.
2. With a narrow strip of fabric directly under the line of gathering, stitch over the gathers. The design will be a series of small diamonds.

Note: When smocking a garment, the stitching should be done before the piece is sewn into the garment.

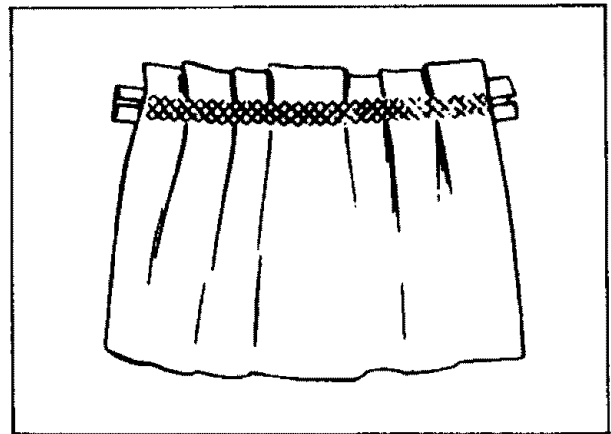
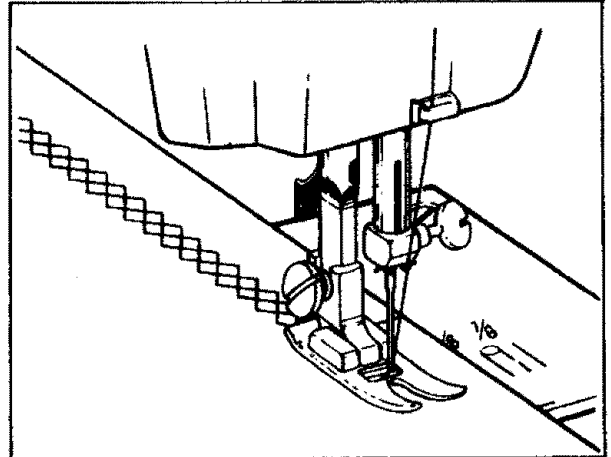

OVERCAST STRETCH STITCH

Stitch Selector - 
Stitch Length - Yellow Zone

This is the same type stitch used by the garment industry in making sportswear-it forms and finishes the seam in one operation (for seams of $\frac{1}{4}$ " to $\frac{3}{8}$ "). It's very effective for use in repairing raw or worn edges of older garments.

Note: To sew overcast stretch stitch in the opposite direction, use serging (or pine leaf) stretch stitch.

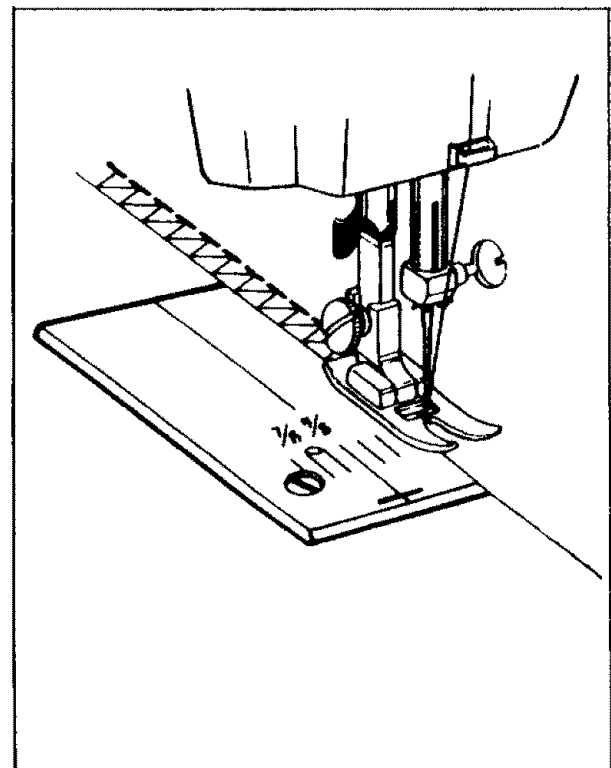

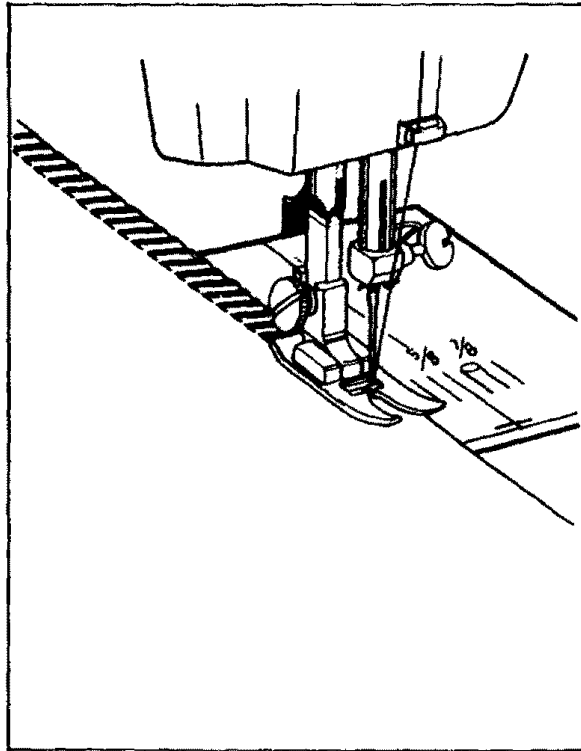



SERGING (OR PINE LEAF) STRETCH STITCH

Stitch Selector - 
Stitch Length - Yellow Zone

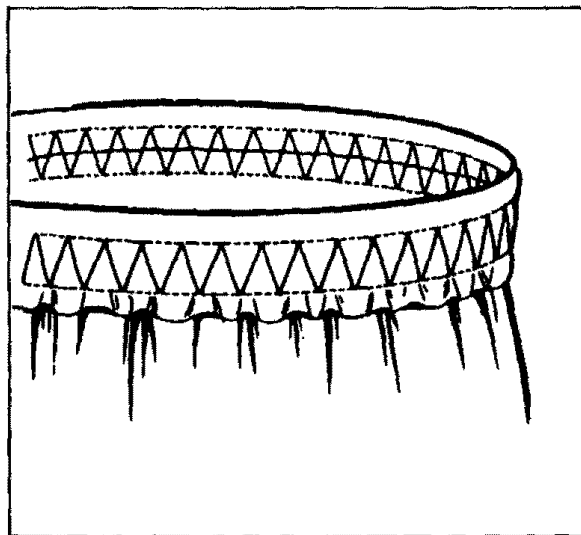
Great in making elastic swimwear—as well as for overcasting a neat edge on seams. It's equally useful with woven and knitted fabrics. Tension may need to be tightened to achieve desired look.



ELASTIC STRETCH STITCH

Stitch Selector - 
Stitch Length - Yellow Zone

Use this versatile stitch to insert elastic in garments. Simply stitch elastic into place, making sure it is evenly spaced. To do this, mark the correct length piece into quarters, then match these markings with center front and side seams.

WHERE TO USE WHICH STRETCH STITCH: A CHECK-CHART







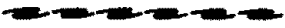

Some stretchy suggestions...

Loosely constructed knits sometimes catch over toes of presser foot. To remedy this, wrap short strip of transparent tape around the foot encasing both toes.

To avoid tangled threads when working with knits, start seams carefully. Position fabric and lower needle before lowering presser foot.

It is always a good idea to test thread tension and stitches on a scrap of the fabric being used.

Knits contain more yarn than woven fabrics, so you will need to take greater care to keep your machine clean specially in feed dog and bobbin case area.

Specially for Stretch	
 STRAIGHT STRETCH	Use on stretch and knit fabrics and to repair ready made garments at stress points. Basic stitch for all garment seams requiring "give" (i. e. armholes, crotch area, etc.). Use also to sew center seam of men's neck ties and seams cut on the bias.
 RICK-RACK STRETCH	A basic multi-purpose stretch stitch with same usage as zigzag stitch, especially for lightweight stretch fabrics.
 SMOCKING STRETCH	A decorative stitch for use on children's clothing, lingerie, yokes of blouses, dress bodice.
 ELASTIC STRETCH	Use to apply elastic to top of lingerie or to repair ready-made lingerie and replace or restitch elastic.
 OVERCAST STRETCH	Use on sportswear where 1/2" seams are required. Makes and finishes seams at same time.
 SERGING OR PINE LEAF	Use for overcasting fabrics that ravel or fray easily... and for seams that need a great deal of stretch (i. e. swimwear, other sportswear, girdles). Also good-looking!
"Everyday" Stitches with Stretch Applications	
 PLAIN ZIGZAG	Use for all-purpose stretch sewing, seam finishing, edge finishing, or attaching stretch laces.
 SHELL STITCH	A good finishing stitch for nylon tricot lingerie.

BUTTONHOLE MAKING - BUILT-IN SYSTEM (BAR-TACK BUTTONHOLES)

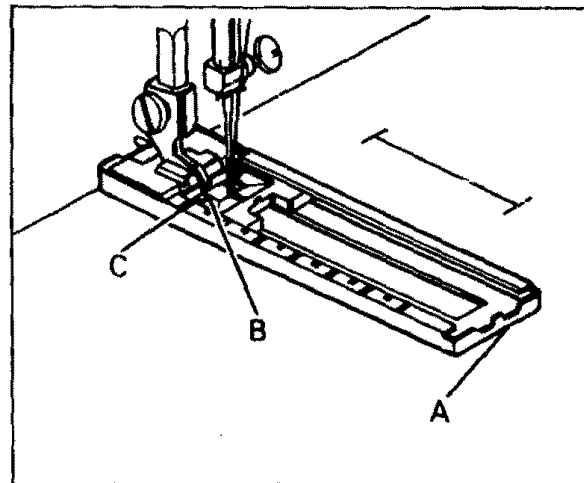
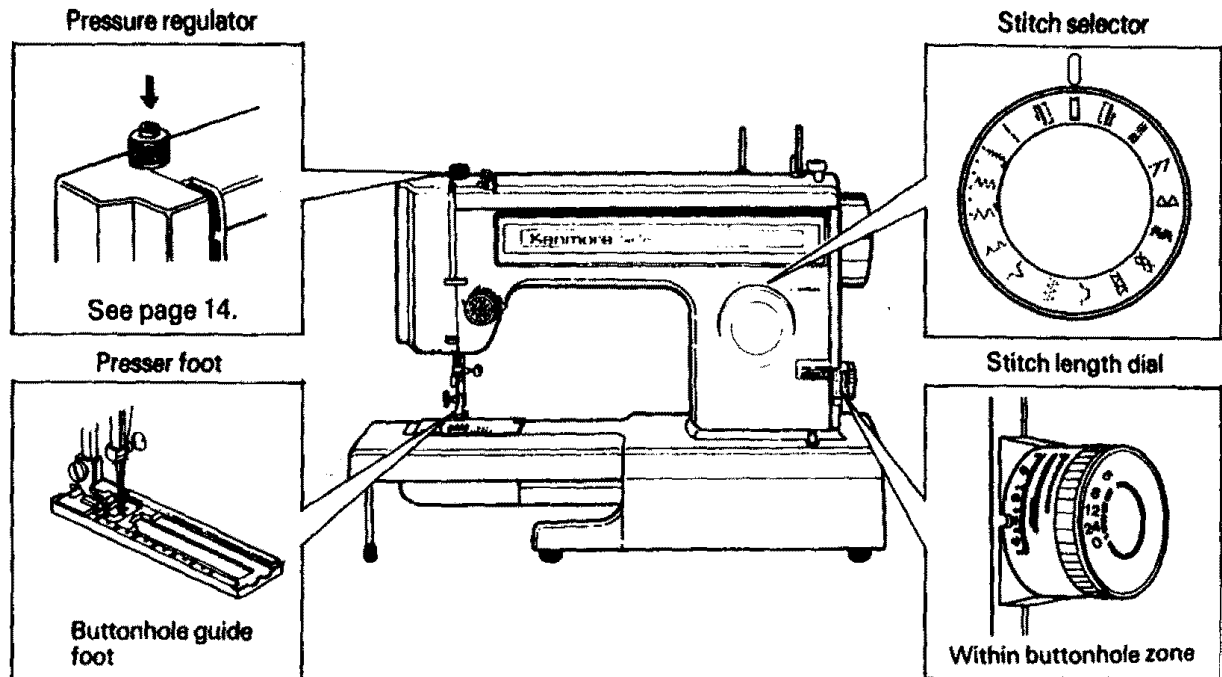

PREPARATION

Carefully mark the buttonhole length on your garment. Place the fabric with the buttonhole marked under the buttonhole foot. Pull the guide foot (A) all the way forward so that the index mark (B) is aligned with the graduation (C), with thread to rear.

Reproduction of the identical size buttonhole is facilitated with the aid of the graduation on the left side of the buttonhole guide foot. These graduations are 1/8" apart. Graduations act as reference mark.

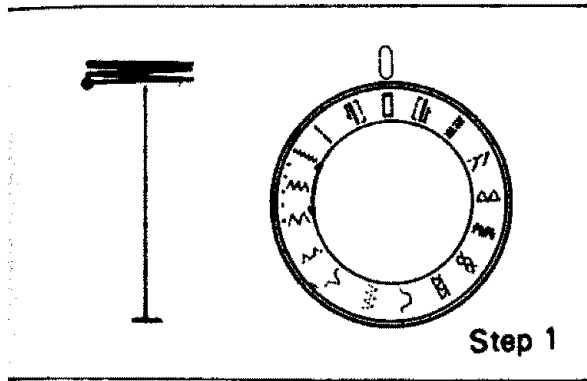

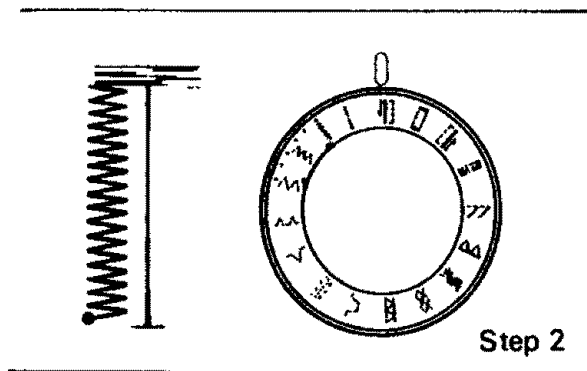

PROCEDURE

Set stitch selector at  and sew several times at the marked beginning of the buttonhole. Stop sewing at the left stitch. Raise needle to its highest position by turning handwheel toward you manually.

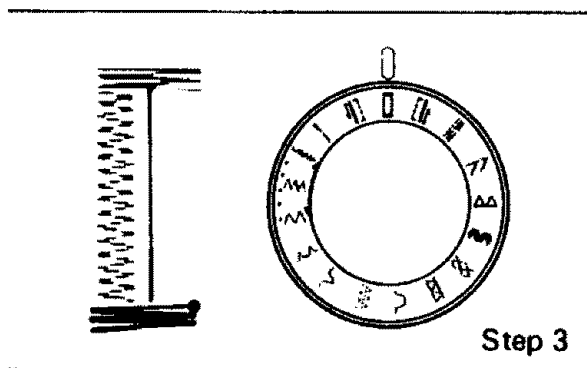

Set stitch selector at . Stitch forward until you approach the front marking of the buttonhole. Stop sewing at the left stitch and raise needle to its highest position.



Set stitch selector at  again and sew several times. Stop sewing at the right stitch and raise needle to its highest position.

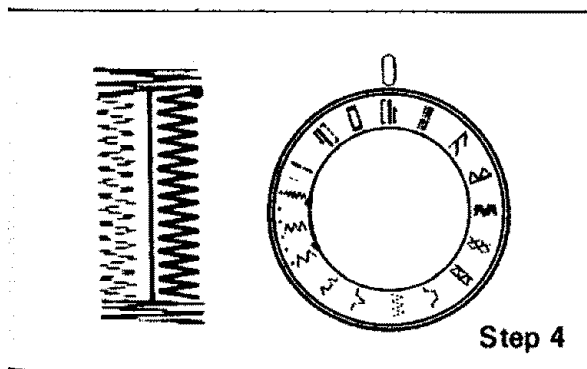

Set stitch selector at  and finish buttonhole.

Use buttonhole opener provided in accessory box to open buttonhole.

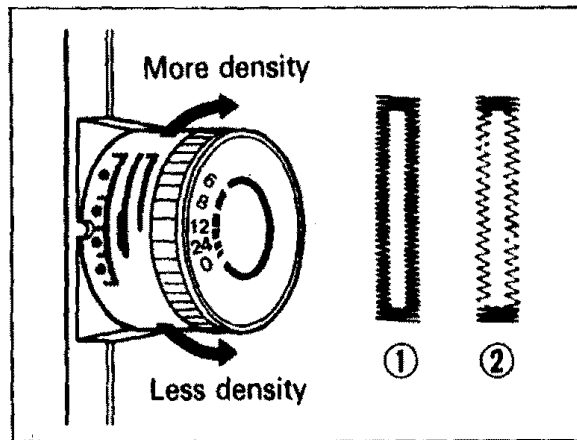

ADJUSTING STITCH DENSITY

Depending upon the fabrics on which you are sewing, or your own preference in buttonholes, you may alter buttonhole stitch density by varying the original stitch length setting within the green zone.

1. For more density, turn the dial away from you.
2. For less density, turn the dial toward you.

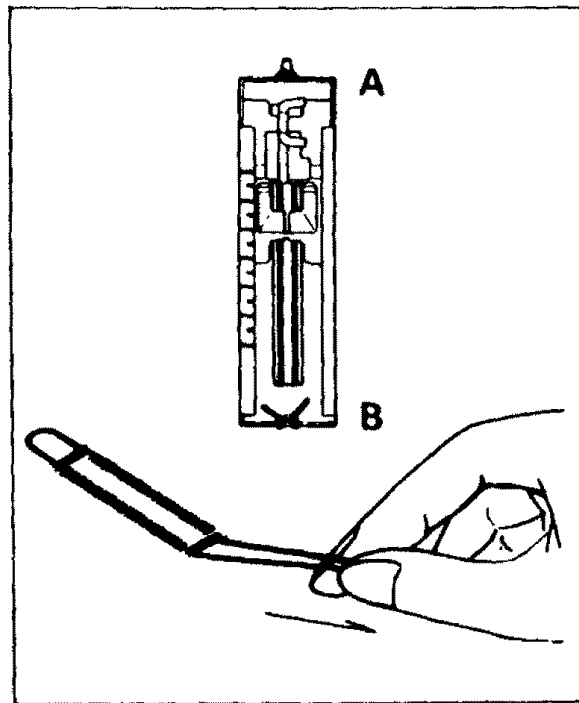

CORDED BUTTONHOLES

Hook filler cord (crotchet thread or buttonhole twist) to the spur (A), pull both ends of cord forward under foot and tie to the spur (B). Sew buttonhole in such a way that zigzag stitches cover the cord.

When stitching is completed, release cord from foot, pull ends of cord and snip off extra length.

BUTTONHOLE MAKING-USING BUTTONHOLE ATTACHMENT

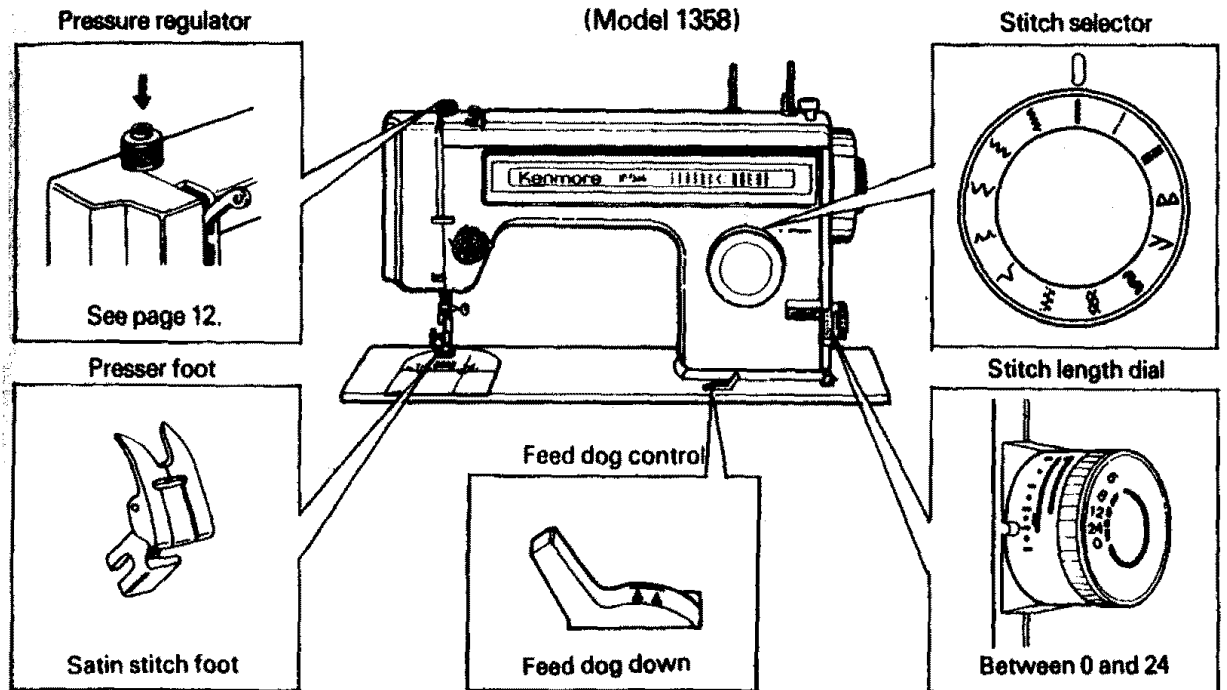

PROCEDURE

1. Raise needle to its highest position and raise presser foot. Remove regular cover plate and insert **buttonhole cover plate**.
2. Screw **guide pin** on **buttonhole guide plate** into **guide pin hole** on needle plate.

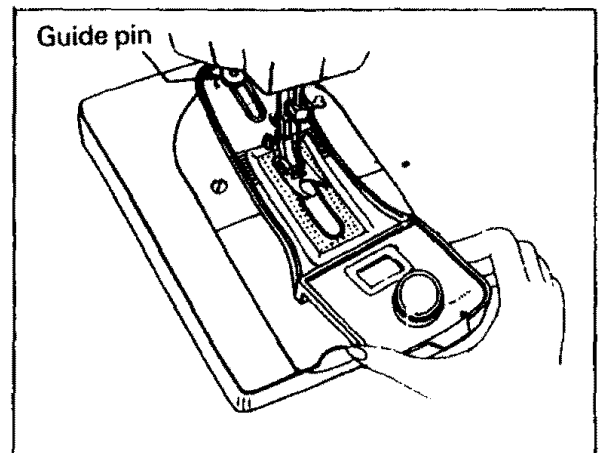
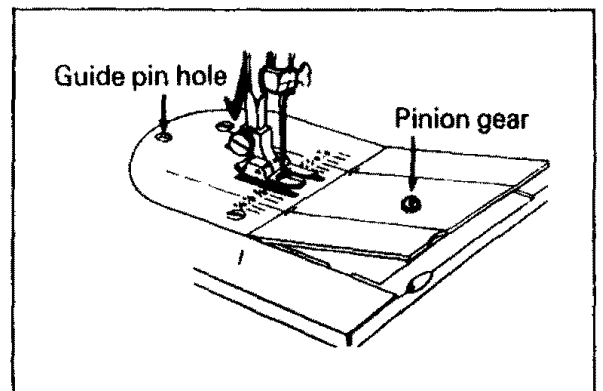

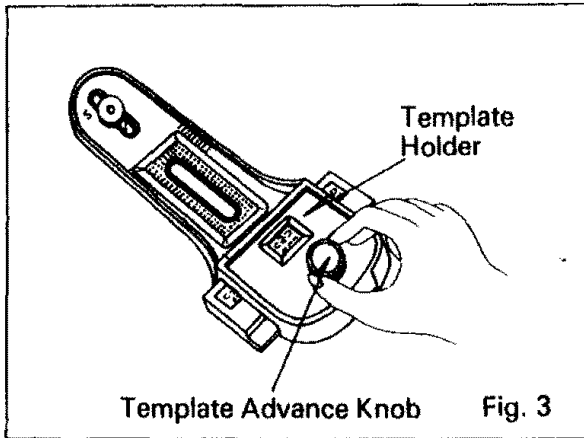

Template Advance Knob Fig. 3

3. Insert a **template** into the slot of **template holder**. Select the proper size of buttonhole by turning the **template advance knob**.

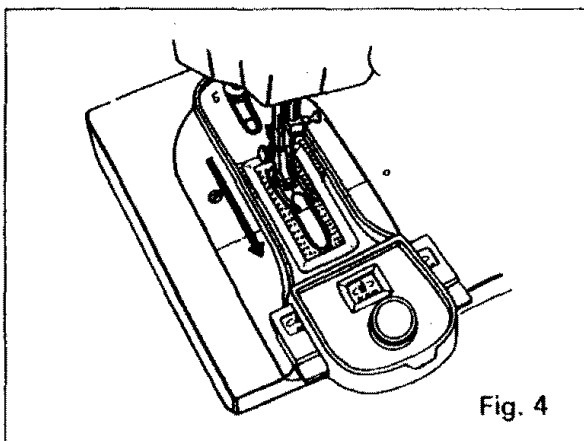

Fig. 4

4. Pull the guide plate all the way forward so that the guide pin is at "S". This will enable you to start at one end of the buttonhole. Drop guide plate into place over the pinion gear.

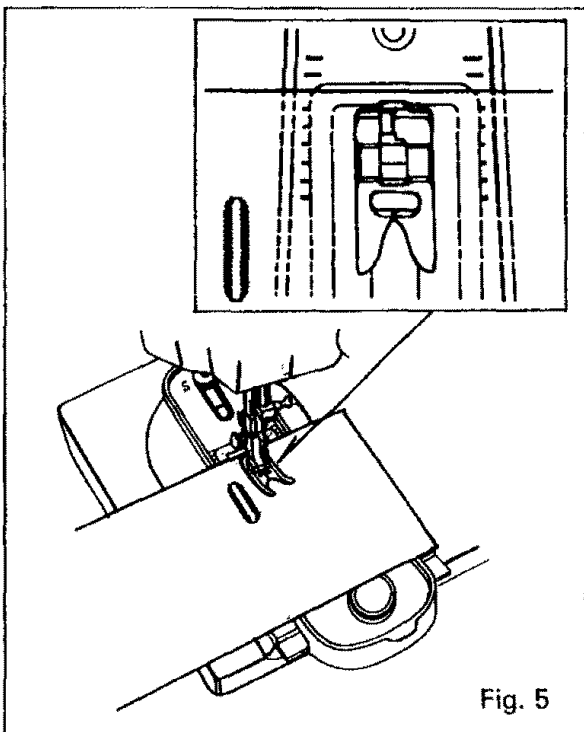
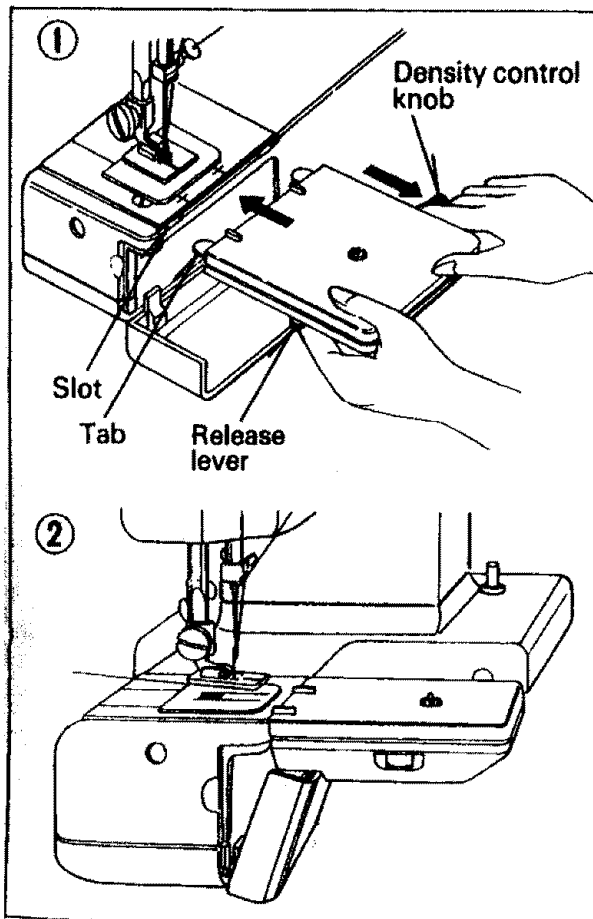
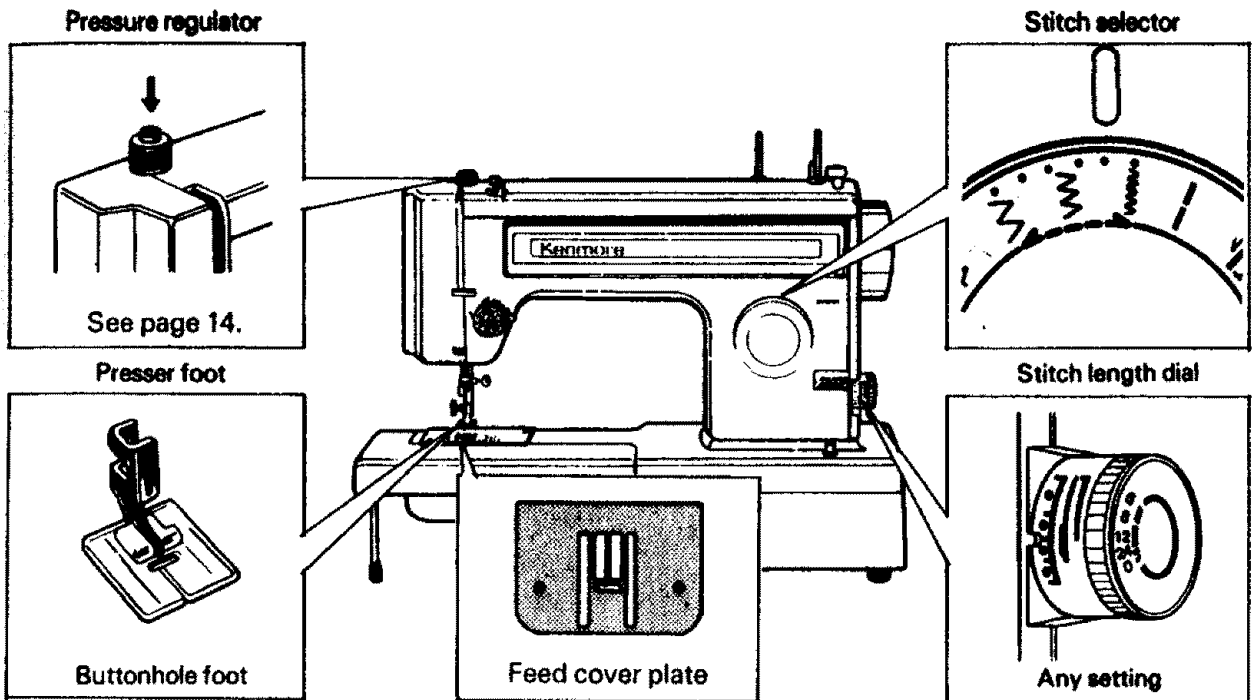

Fig. 5

5. Pick up bobbin thread through guide plate by turning hand wheel and drawing thread to back of machine. Place fabric between presser foot and guide plate. Line up edge of fabric with marked indentation on guide. If you wish all buttonholes to be $\frac{3}{4}$ inch from edge of garment, line up fabric with $\frac{3}{4}$ inch marking each time you start sewing a buttonhole.

BUTTONHOLE MAKING - USING BUTTONHOLE ATTACHMENT



SETTING STITCH SELECTOR

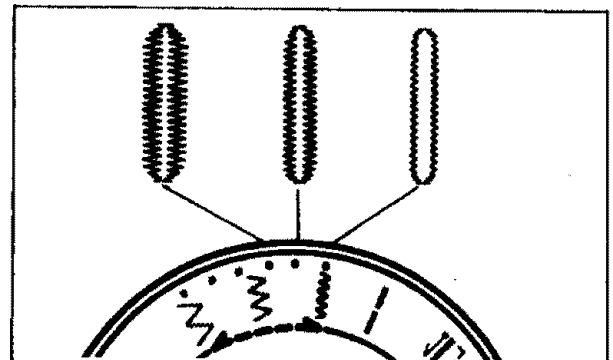

PROCEDURE

1. Raise needle to its highest position and raise the presser foot. Remove the extension table from machine and open shuttle cover.

Insert two tabs of buttonhole adapter into slots under the needle plate pulling density control knob toward you until the adapter snaps into place. (when buttonholing is completed, remove the adapter by pulling it toward you with release lever lifted up.)

2. Swing the shuttle cover up and away until it is locked under the adapter as shown.

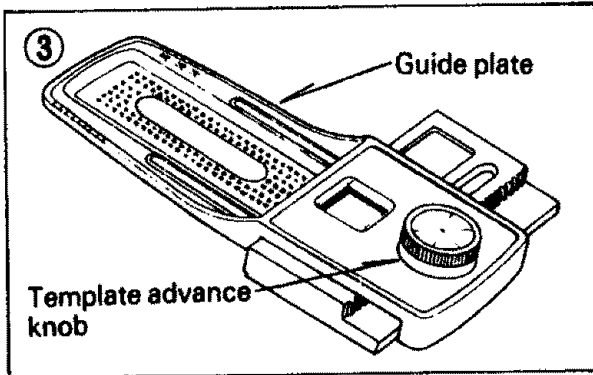

3. Select correct template for type buttonhole you want. Insert template into slot of guide plate. Turn template advance knob to desired size.

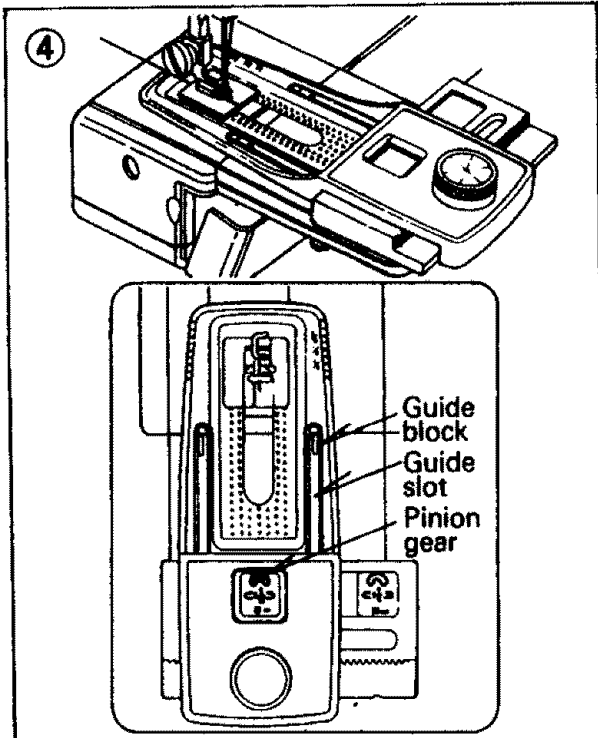

4. Slip guide plate onto machine so it fits in place with pinion gear in the center of arc hole of template. Be sure guide block is inserted in guide slot.

Your machine controls should be set as shown on page 44. You will note that the stitch selector can be set for several stitch widths. This will result in thicker or thinner buttonholes as illustrated on page 44. The type of fabric you use will determine what width you use. Be sure to make a practice buttonhole first.

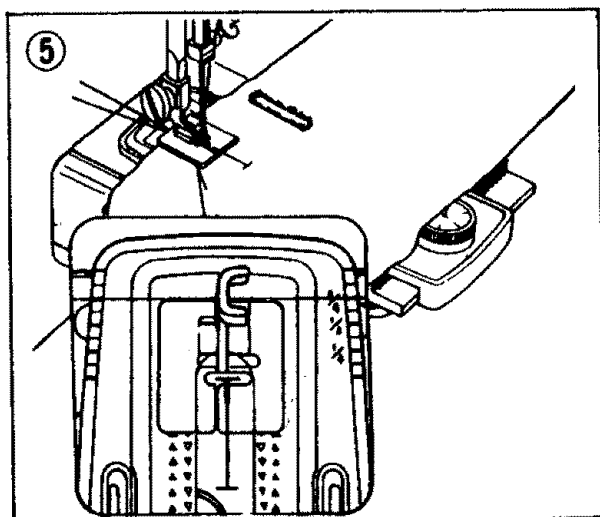

5. Pick up bobbin thread through guide plate by turning hand wheel. Place fabric between presser foot and guide plate. Align marked buttonhole with center marking on foot. Line up edge of fabric with markings on guide plate. If you wish all buttonholes to be 3/4" from edge of garment, for example, line up fabric with 3/4" marking each time you start a buttonhole.

ADJUSTING STITCH DENSITY

Depending upon the fabrics on which you are sewing, or your own preference in buttonholes, you may alter buttonhole stitch density by turning stitch density control knob.

1. When delivered, stitch density control knob will be tightened completely. For more density, turn the knob toward you. If the knob should be loosened as far as it can go during adjustment, retighten it by a quarter to half a turn to assure smooth operation.
2. For less density, turn the knob away from you.

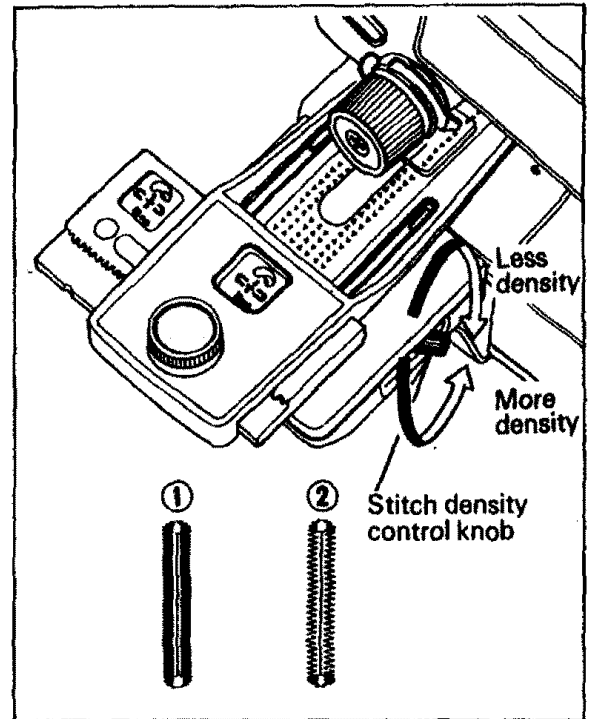

CHOOSING BUTTONHOLE STYLE AND SIZE

Each buttonholing will be different so you will want to experiment with your garment, considering fabric and placement of button. Here are some basic applications:

Straight buttonholes are most popular for everyday sewing — for series of buttons on dress, blouse, vest, jacket or coat.

Keyhole buttonholes are a variation of the above, with an enlarged opening at one end

to allow more room for button shank. These are normally used in tailored vests, jackets, coats.

Eyelet buttonholes (another variation of "straight") most often are used for studs on skirts or holes for tongues of belt buckles.

**ROUND END
STRAIGHT
BUTTONHOLE**

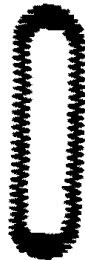

**KEYHOLE
BUTTONHOLE**

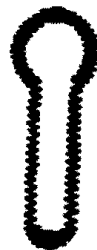

**EYELET
BUTTONHOLE**



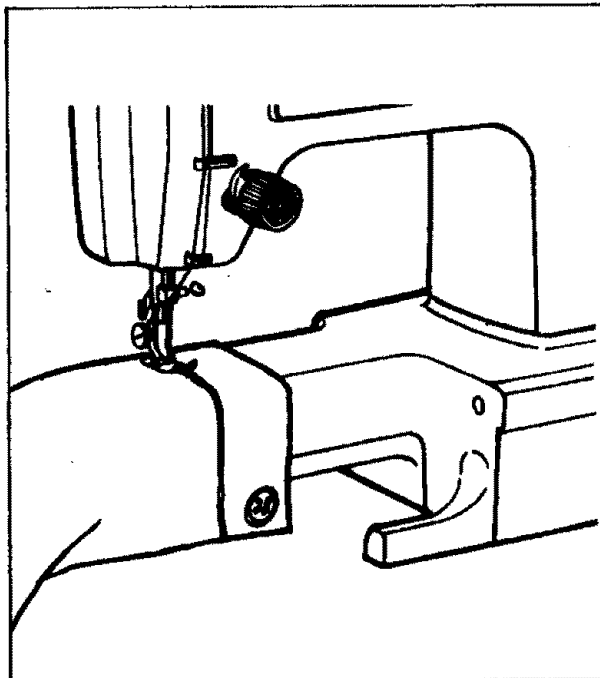

FREE-ARM SEWING

Your Kenmore sewing machine is easily converted from a traditional flat-bed to a contemporary free-arm sewing machine by removing extension table.

The free arm enables you to sew tubular types of pieces more easily. Just slip the sleeve or pants leg on the free arm as shown.

You will find many uses for this free arm feature such as:

1. Mend elbows and knees of garments more easily.
2. Sew in sleeves more easily. This is especially true when sewing smaller garments.
3. Applique, embroider or hem around edges of cuffs or pants legs.
4. Sewing in elastic casings in skirts or pants at the waistline.

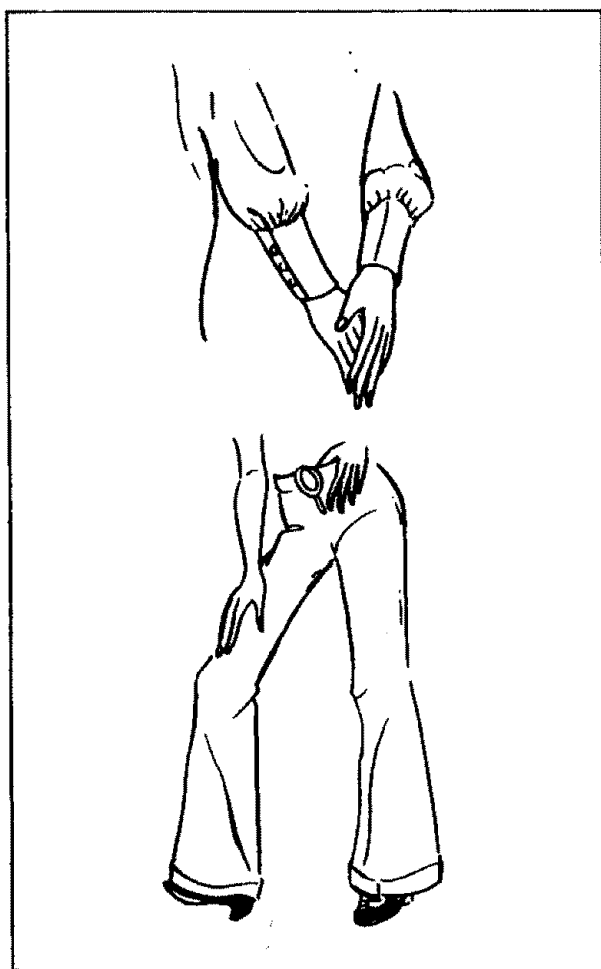

SEWING MACHINE

Now that you have purchased your Kenmore Sewing Machine, should a need ever exist for repair parts or service, simply contact any Sears Service Center and most Sears, Roebuck and Co. Stores. Be sure to provide all pertinent facts when you call or visit.

The model number of your Sewing Machine will be shown on your nomenclature plate on the back of your Sewing Machine. See page 3 for location.

WHEN ORDERING REPAIR PARTS, ALWAYS GIVE THE FOLLOWING INFORMATION:

***MODEL NUMBER *NAME OF ITEM *PART DESCRIPTION**

If the parts you need are not stocked locally, your order will be electronically transmitted to a Sears Repair Parts Distribution Center for handling.

SEARS, ROEBUCK AND CO., Chicago, IL 60684 U.S.A.